

2

BPG

Glass Reinforced Polyester Enclosures

SX Range
1

BPG Range
2

BPGA Range
3

ZAG Range
4

High Voltage
5

Fire Rated
6

ZP Range
7

Others
8

Technical
9

Further details on this range of enclosures can be found at;

www.ab-tech.co.uk/bpg.htm



Glass Reinforced Polyester Enclosures

The BPG range comprises 16 sizes of enclosure manufactured in glass reinforced polyester (GRP). This material is highly resistant to contamination from oils, fats, aliphatic and aromatic carbohydrates, bacteria and enzymes. It is also suitable for LSOH (low smoke zero halogen) applications.

Polyester gives excellent mechanical strength and life expectancy. The wall thickness is sufficient to allow tapped entry holes to be machined in the walls of the enclosure and it provides a very good alternative to aluminium or cast iron.



ABTECH mould the BPG range from SMC material rather than DMC which is the most common form of GRP. In this method the glass reinforcement takes the form of sheets rather than short strands. This gives much greater mechanical strength and also in the event of the enclosure being exposed to fire conditions the structure holds together even if the resin is depleted due to the elevated temperatures.

This is demonstrated by the fact that the BPG range when fitted with ceramic terminals meets the requirements of IEC 331 (750°C (1382°F) for 3 hours) and also BS6387/1983 (950°C (1742°F) for 3 hours - flame only). Further information about this testing procedure can be found in Section 6 of this catalogue.



Due to the enclosure's labyrinth seal system, whereby the seal is protected from external forces, the BPG range has excellent ingress protection qualities which mean that the enclosures are tested to and passed IP66/67. They have also undergone and passed the Shell/ERA deluge test which was devised to adequately test enclosures and electrical equipment which is routinely subjected to ship decks conditions or fire deluge systems.

The mounting holes, although contained within the profile of the enclosure, sit outside the seal and all external fasteners and fixings are manufactured from 316 grade stainless steel to ensure reliability.

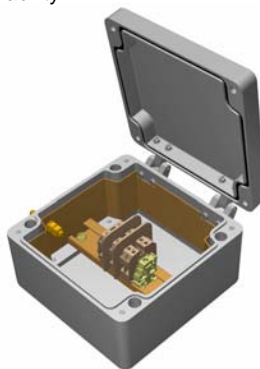

The BPG range has many features which lend itself to a whole host of applications including both industrial and hazardous area junction boxes, OEM applications, fire protection systems, tunnel wiring etc.

The BPG range can be machined, drilled, tapped with various thread forms, painted and of course it can be moulded in a variety of colours which gives a much improved durability of colour over painting.

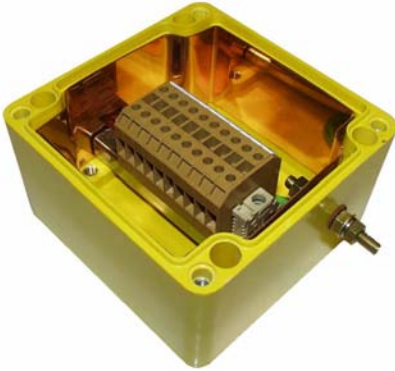

The BPG range is also available carbon loaded (BPGC) which helps to reduce the surface resistance of the material and consequently reduce the risk of spark from static build up.

Earthing can be accomplished by various means. Internal / external earth stud which in turn can be connected to the terminal mounting rail or component mounting plate, an earth continuity plate (ECP) can be fitted around the inner walls to provide continuity for cable glands and various rail mounted earth terminals or proprietary earth bars can be fitted inside the enclosure.

When fitted with a standard neoprene gasket, the enclosure is suitable for ambient temperatures of - 40°C to + 80°C (-40°F to +176°F). Alternatively, when fitted with an optional silicone gasket the temperature range is increased to - 70°C to + 130°C (-94°F to +266°F). For certified apparatus contact the ABTECH Sales department for ambient operating temperatures.

The BPG and BPGC enclosures are suitable for use in hazardous areas and can be supplied with a number of certificates, specifically ATEX EEx'e' to BS EN 50019 (zone 1 & 2) EEx'nA' to BS EN50021 (zone 2) and NEMA 4X (CSA, UL & FM class 1, div 2).



The BPG range can be supplied fitted with any component approved terminal to apparatus level or can be supplied empty as component approved for the clients own certification requirements.

BPG Range Features

- Wide Operating Temperature (- 70°C to + 130°C) (-94°F to +266°F)
- Ingress Protection up to IP67
- Fire Resistant to IEC331
- Impact Resistant > 7Nm
- UV Resistant
- Can be drilled and tapped to accommodate most thread forms (NPT for example)
- Certification for use in Zone 1 and 2
- UL, CSA, IECEx, ATEX, InMetro and GOST Approvals
- Ideal for Petrochemical and Marine applications

SX Range 1

BPG Range 2

BPGA Range 3

ZAG Range 4

High Voltage 5

Fire Rated 6

ZP Range 7

Others 8

Technical 9

Accessories and Options

The following table is a list of the available accessories suitable for a particular size of BPG enclosure. Care should be taken when ordering accessories for use with enclosures intended for hazardous areas to ensure that compliance with certification is retained.

2
BPG Range

Part Number	Width (mm)	Length (mm)	Depth (mm)	C - Carbon Loaded (see note 1)	EX - Ex Certified (see note 2)	EC - Earth Continuity Plate	ES - Earth Stud	AS - Allen Head Fixing Screws	TP - Tamper Proof Screws	EH - External Hinges	MP - Component Mounting Plate	MF - External Mounting Feet	EB - Internal Earthing Bar	SG - Silicone Gasket (see note 3)	MR - DIN Standard Mounting Rail	RF - RFI Protection (see note 4)
BPG1	80	75	55	✓	✓	✗	✗	✓	✓	✓	✓	✓	✗	✓	✓	✓
BPG2	110	75	55	✓	✓	✗	✗	✓	✓	✓	✓	✓	✗	✓	✓	✓
BPG3	160	75	55	✓	✓	✗	✗	✓	✓	✓	✓	✓	✗	✓	✓	✓
BPG4	190	75	55	✓	✓	✗	✗	✓	✓	✓	✓	✓	✗	✓	✓	✓
BPG4.5	190	75	75	✓	✓	✗	✗	✓	✓	✓	✓	✓	✗	✓	✓	✓
BPG5	230	75	55	✓	✓	✗	✗	✓	✓	✓	✓	✓	✗	✓	✓	✓
BPG6	122	120	90	✓	✓	✓	✓	✓	✓	✓	✓	✓	✓	✓	✓	✓
BPG7	220	120	90	✓	✓	✓	✓	✓	✓	✓	✓	✓	✓	✓	✓	✓
BPG8	160	160	90	✓	✓	✓	✓	✓	✓	✓	✓	✓	✓	✓	✓	✓
BPG9	260	160	90	✓	✓	✓	✓	✓	✓	✓	✓	✓	✓	✓	✓	✓
BPG10	360	160	90	✓	✓	✓	✓	✓	✓	✓	✓	✓	✓	✓	✓	✓
BPG11	560	160	90	✓	✓	✓	✓	✓	✓	✓	✓	✓	✓	✓	✓	✓
BPG12	255	250	120	✓	✓	✓	✓	✓	✓	✓	✓	✓	✓	✓	✓	✓
BPG13	400	250	120	✓	✓	✓	✓	✓	✓	✓	✓	✓	✓	✓	✓	✓
BPG13.5	400	250	140	✓	✓	✓	✓	✓	✓	✓	✓	✓	✓	✓	✓	✓
BPG14	600	250	120	✓	✓	✓	✓	✓	✓	✓	✓	✓	✓	✓	✓	✓
BPG15	400	405	120	✓	✓	✓	✓	✓	✓	✓	✓	✓	✓	✓	✓	✓

Ordering Example;

BPG8 EX EC EB MR

(BPG8 EX Certified with Earth Continuity Plate, Internal Earthing Bar and DIN standard Mounting Rail)

1. Carbon loading gives a surface tracking value of between 10MΩ and 10GΩ. Surface colour is black.
2. EEx'e certification may be component or apparatus certified - please specify your requirements.
3. Silicone gasket increases temperature rating (-70° to +130° C) (-94F to +266F).
4. Radio Frequency Interference (RFI) gasket may reduce IP rating. Enclosure may also be internally coated with RFI material.

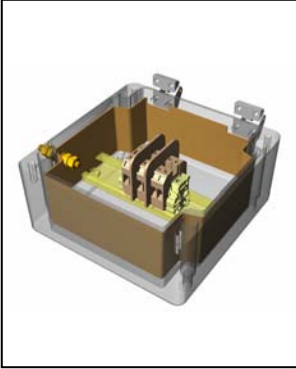

Copper earth continuity plate
(must also be fitted with earth stud)

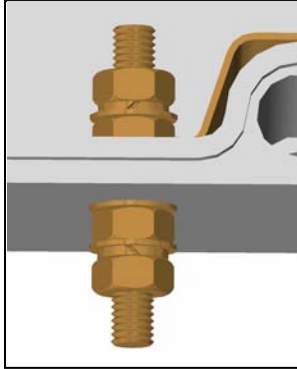

Earth Stud
(either brass or stainless steel)



Allen Head fixing screws
(grade 316)

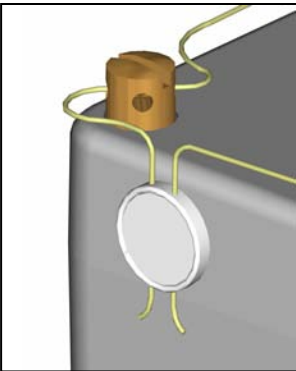

Tamper-proof screws



External hinges

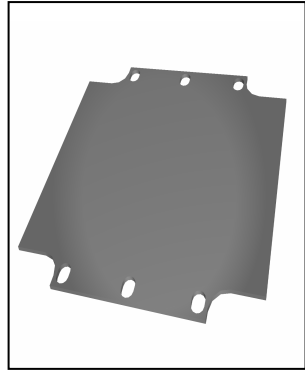

Component mounting plate
(tufnol as standard, steel an option)

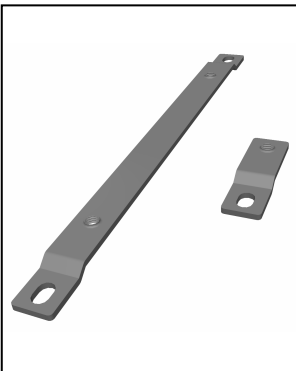

External mounting feet
(stainless steel 316)

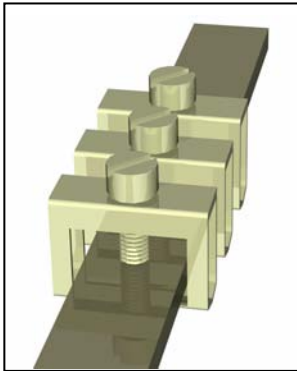

Internal Earthing bar
(can be fitted with clamps)



DIN standard mounting rail
(TS15, TS32 or TS35)

SX Range 1

BPG Range 2

BPGA Range 3

ZAG Range 4

High Voltage 5

Fire Rated 6

ZP Range 7

Others 8

Technical 9

We can also supply cable glands, stopping plugs, breather drains and continuity plates. Please contact us for further details.

BPG 1 / BPGC 1 Drawing

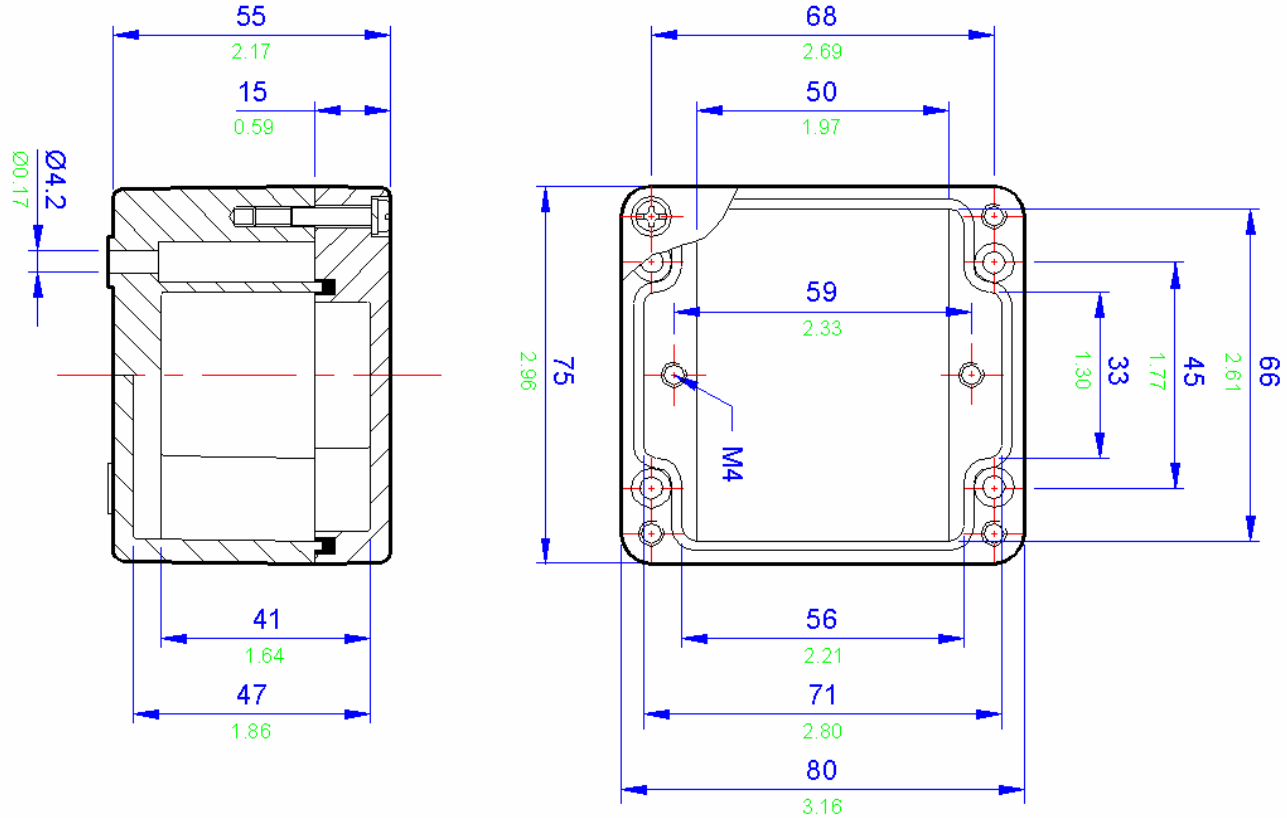

All blue dimensions in mm, all green dimensions in decimal inches (drawing not to scale)

BPG 1 / BPGC 1 Specifications	
Width	80mm
Length	75mm
Depth	55mm
Material	BPG1 - Glass Reinforced Polyester (RAL7001 grey)
	BPGC1 - Carbon Loaded Glass Reinforced Polyester (Black)
Weight	230g
IP Rating	66/67
Temperature	-40° to 80° C (-40°F to +176°F) (standard neoprene gasket)
	-70° to 130° C (-94°F to +266°F) (silicone gasket)
Certification	ATEX EEx'e' BS EN 50019 (Zone 1 & 2)
	ATEX EEx'nA' BS EN 50021 (Zone 2)
	NEMA 4X (CSA & UL) (class 1 division 2)
	GOST-R Ex'e' (Zone 1 & 2)
Power Rating	8.390W

Terminal Populations			
Maximum Number of Rows			1
Weidmuller		Wago	
BK4 (4 way)	1	280-992	0
BK6 (6 way)	1	280-999	0
BK12 (12 way)	0	281-691	0
MK6/3	1	281-992	0
MK6/4	1	281-993	0
MK6/6	0	282-691	0
SAK2.5	0	284-691	0
SAK4	0	283-691	0
SAK6N	0	285-691	0
SAK10	0	280-998	0
SAK16	0	281-998	0
SAK35	0	264-120	8
Entretec		264-220	4
MA2.5/5	0	264-132 (2)	0
M4/6	0	264-134 (4)	0
M6/8	0	262-132 (2)	0
M10/10	0	262-134 (4)	0
M16/12	0		
M35/16	0		

Cable Gland Entry Matrix		
Entry Size	Side A-C	Side B-D
M16	1	0
M20	0	0
M25	0	0
M32	0	0
M40	0	0

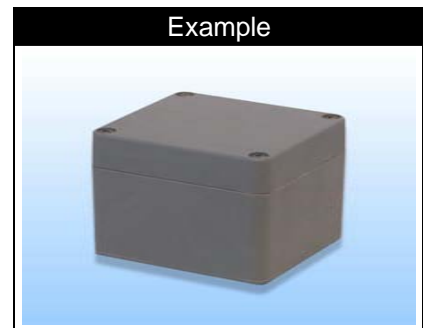
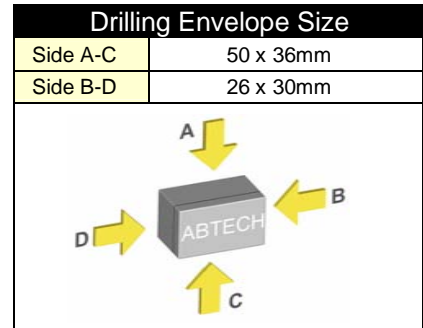

BPG 2 / BPGC 2 Drawing

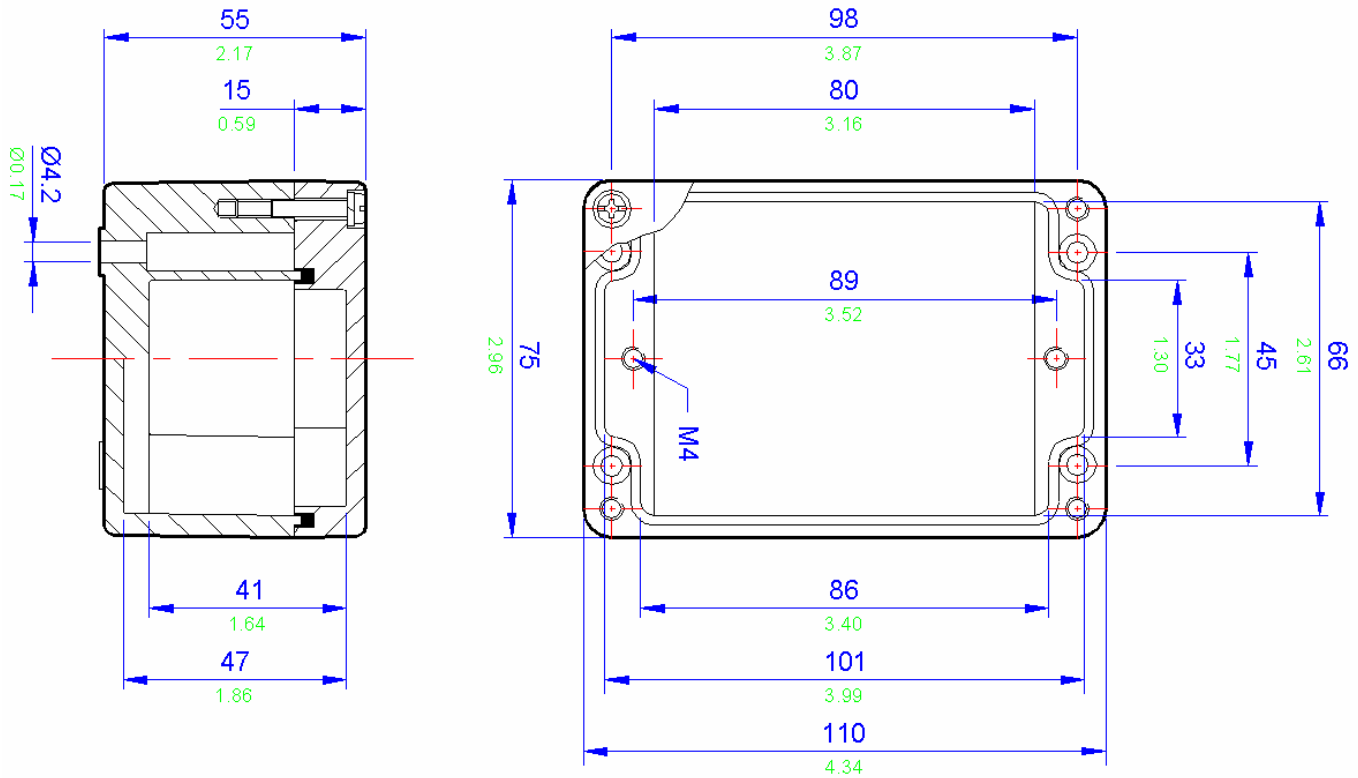

All blue dimensions in mm, all green dimensions in decimal inches (drawing not to scale)

BPG 2 / BPGC 2 Specifications

Width	110mm
Length	75mm
Depth	55mm
Material	BPG2 - Glass Reinforced Polyester (RAL7001 grey)
	BPGC2 - Carbon Loaded Glass Reinforced Polyester (Black)
Weight	230g
IP Rating	66/67
Temperature	-40° to 80° C (-40°F to +176°F) (standard neoprene gasket)
	-70° to 130° C (-94°F to +266°F) (silicone gasket)
Certification	ATEX EEx'e' BS EN 50019 (Zone 1 & 2)
	ATEX EEx'nA' BS EN 50021 (Zone 2)
	NEMA 4X (CSA & UL) (class 1 division 2)
	GOST-R Ex'e' (Zone 1 & 2)
Power Rating	8.551W

Terminal Populations

Maximum Number of Rows		1	
Weidmuller		Wago	
BK4 (4 way)	2	280-992	0
BK6 (6 way)	1	280-999	0
BK12 (12 way)	1	281-691	0
MK6/3	1	281-992	0
MK6/4	1	281-993	0
MK6/6	1	282-691	0
SAK2.5	0	284-691	0
SAK4	0	283-691	0
SAK6N	0	285-691	0
SAK10	0	280-998	0
SAK16	0	281-998	0
SAK35	0	264-120	12
Entrelec		264-220	7
MA2.5/5	0	264-132 (2)	2
M4/6	0	264-134 (4)	1
M6/8	0	262-132 (2)	2
M10/10	0	262-134 (4)	1
M16/12	0		
M35/16	0		

Cable Gland Entry Matrix

Entry Size	Side A-C	Side B-D
M16	2	0
M20	0	0
M25	0	0
M32	0	0
M40	0	0

Drilling Envelope Size

Side A-C	80 x 36mm
Side B-D	26 x 30mm

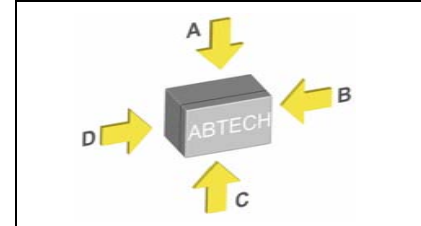

Example



BPG 3 / BPGC 3 Drawing

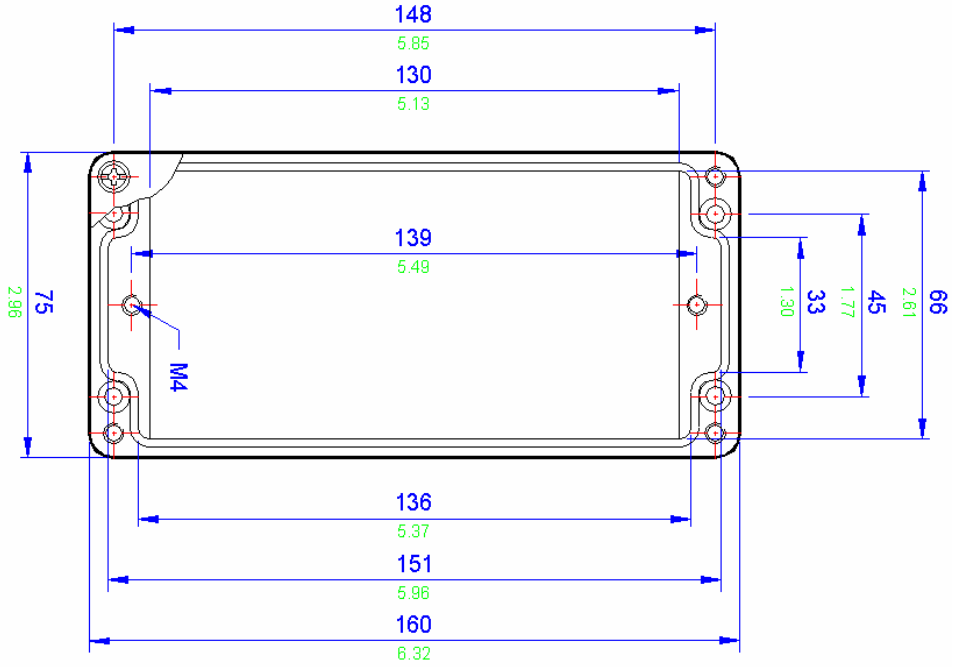
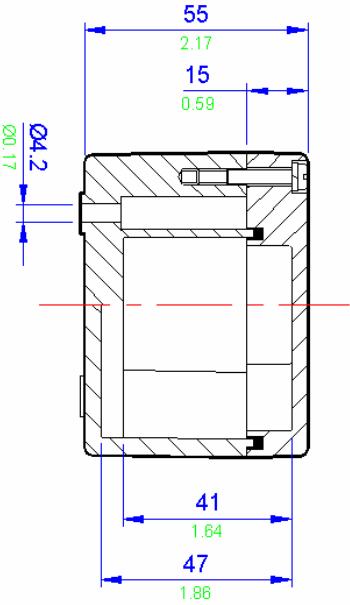

All blue dimensions in mm, all green dimensions in decimal inches (drawing not to scale)

BPG 3 / BPGC 3 Specifications

Width	160mm
Length	75mm
Depth	55mm
Material	BPG3 - Glass Reinforced Polyester (RAL7001 grey)
	BPGC3 - Carbon Loaded Glass Reinforced Polyester (Black)
Weight	405g
IP Rating	66/67
Temperature	-40° to 80° C (-40°F to +176°F) (standard neoprene gasket)
	-70° to 130° C (-94°F to +266°F) (silicone gasket)
Certification	ATEX EEx'e' BS EN 50019 (Zone 1 & 2)
	ATEX EEx'nA' BS EN 50021 (Zone 2)
	NEMA 4X (CSA & UL) (class 1 division 2)
	GOST-R Ex'e' (Zone 1 & 2)
Power Rating	8.833W

Terminal Populations

Maximum Number of Rows		1	
Weidmuller		Wago	
BK4 (4 way)	3	280-992	0
BK6 (6 way)	2	280-999	0
BK12 (12 way)	1	281-691	0
MK6/3	2	281-992	0
MK6/4	2	281-993	0
MK6/6	1	282-691	0
SAK2.5	0	284-691	0
SAK4	0	283-691	0
SAK6N	0	285-691	0
SAK10	0	280-998	0
SAK16	0	281-998	0
SAK35	0	264-120	19
Entrelec		264-220	11
MA2.5/5	0	264-132 (2)	4
M4/6	0	264-134 (4)	3
M6/8	0	262-132 (2)	4
M10/10	0	262-134 (4)	3
M16/12	0		
M35/16	0		

Cable Gland Entry Matrix

Entry Size	Side A-C	Side B-D
M16	4	0
M20	0	0
M25	0	0
M32	0	0
M40	0	0

Drilling Envelope Size

Side A-C	130 x 36mm
Side B-D	27 x 29mm

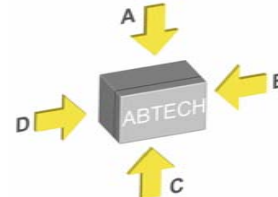

Example



BPG 4 / BPGC 4 Drawing

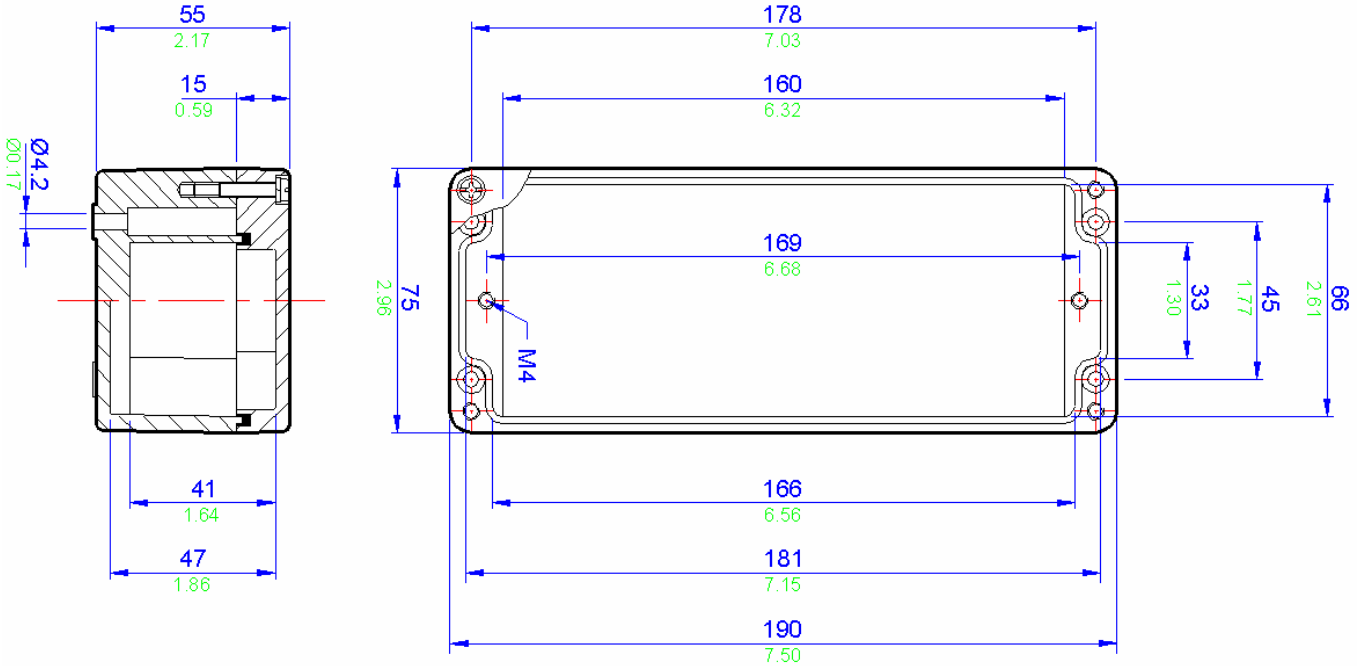

All blue dimensions in mm, all green dimensions in decimal inches (drawing not to scale)

BPG 4 / BPGC 4 Specifications	
Width	190mm
Length	75mm
Depth	55mm
Material	BPG4 - Glass Reinforced Polyester (RAL7001 grey)
	BPGC4 - Carbon Loaded Glass Reinforced Polyester (Black)
Weight	450g
IP Rating	66/67
Temperature	-40° to 80° C (-40°F to +176°F) (standard neoprene gasket)
	-70° to 130° C (-94°F to +266°F) (silicone gasket)
Certification	ATEX EEx'e' BS EN 50019 (Zone 1 & 2)
	ATEX EEx'nA' BS EN 50021 (Zone 2)
	NEMA 4X (CSA & UL) (class 1 division 2)
	GOST-R Ex'e' (Zone 1 & 2)
Power Rating	9.012W

Terminal Populations			
Maximum Number of Rows			1
Weidmuller		Wago	
BK4 (4 way)	4	280-992	0
BK6 (6 way)	2	280-999	0
BK12 (12 way)	1	281-691	0
MK6/3	3	281-992	0
MK6/4	3	281-993	0
MK6/6	2	282-691	0
SAK2.5	0	284-691	0
SAK4	0	283-691	0
SAK6N	0	285-691	0
SAK10	0	280-998	0
SAK16	0	281-998	0
SAK35	0	264-120	25
Entrelec		264-220	15
MA2.5/5	0	264-132 (2)	5
M4/6	0	264-134 (4)	3
M6/8	0	262-132 (2)	5
M10/10	0	262-134 (4)	3
M16/12	0		
M35/16	0		

Cable Gland Entry Matrix		
Entry Size	Side A-C	Side B-D
M16	5	0
M20	0	0
M25	0	0
M32	0	0
M40	0	0

Drilling Envelope Size	
Side A-C	160 x 36mm
Side B-D	27 x 30mm

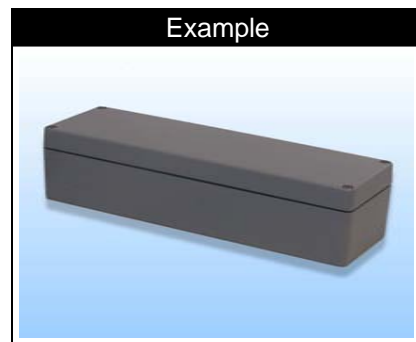
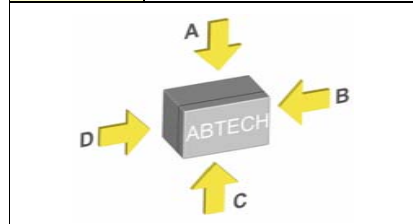

Technical 9	Others 8	ZP Range 7	Fire Rated 6	High Voltage 5	ZAG Range 4	BPGA Range 3	BPG Range 2	SX Range 1
----------------	-------------	---------------	-----------------	-------------------	----------------	-----------------	------------------------	---------------

BPG 4.5 / BPGC 4.5 Drawing

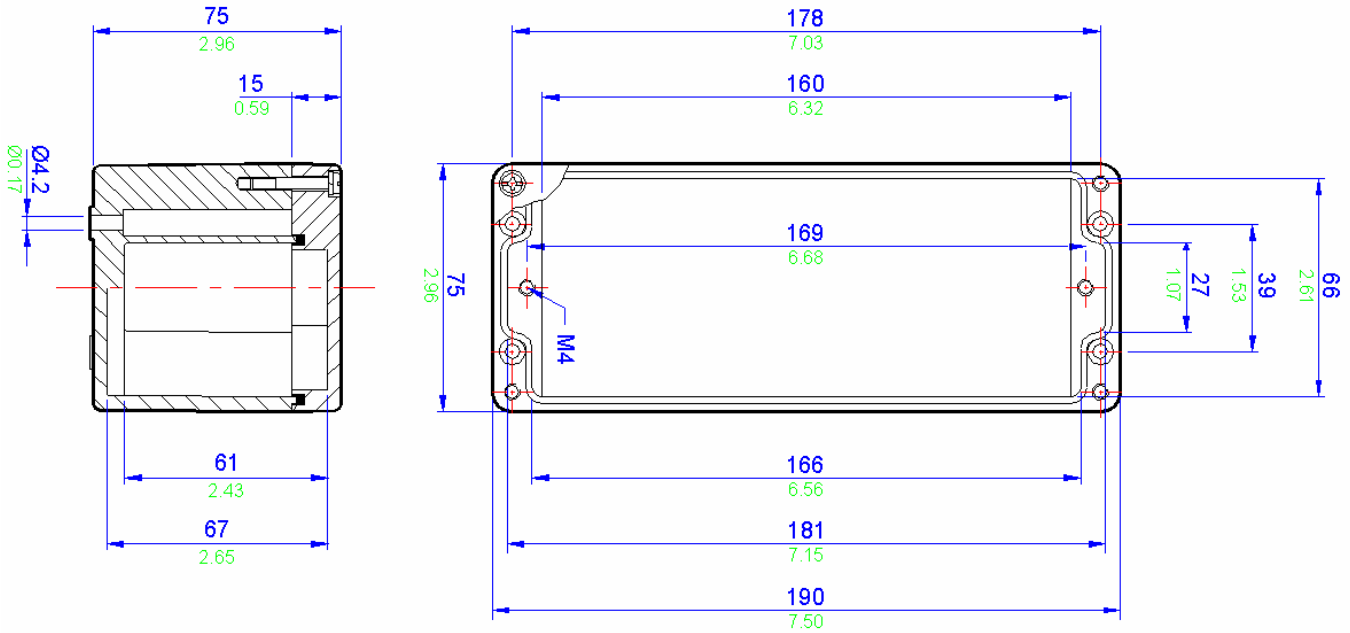

All blue dimensions in mm, all green dimensions in decimal inches (drawing not to scale)

BPG 4 .5/ BPGC 4.5 Specifications	
Width	190mm
Length	75mm
Depth	75mm
Material	BPG4.5 - Glass Reinforced Polyester (RAL7001 grey)
	BPGC4.5 - Carbon Loaded Glass Reinforced Polyester (Black)
Weight	529g
IP Rating	66/67
Temperature	-40° to 80° C (-40°F to +176°F) (standard neoprene gasket)
	-70° to 130° C (-94°F to +266°F) (silicone gasket)
Certification	ATEX EEx'e' BS EN 50019 (Zone 1 & 2)
	ATEX EEx'nA' BS EN 50021 (Zone 2)
	NEMA 4X (CSA & UL) (class 1 division 2)
	GOST-R Ex'e' (Zone 1 & 2)
Power Rating	9.260W

Terminal Populations			
Maximum Number of Rows			1
Weidmuller		Wago	
BK4 (4 way)	4	280-992	28
BK6 (6 way)	3	280-999	0
BK12 (12 way)	1	281-691	24
MK6/3	3	281-992	0
MK6/4	3	281-993	0
MK6/6	2	282-691	0
SAK2.5	25	284-691	0
SAK4	25	283-691	0
SAK6N	19	285-691	0
SAK10 *	17	280-998	28
SAK16	0	281-998	24
SAK35	0	264-120	25
Entrelec		264-220	15
MA2.5/5	30	264-132 (2)	6
M4/6	25	264-134 (4)	4
M6/8	19	262-132 (2)	6
M10/10 *	15	262-134 (4)	4
M16/12 *	12		
M35/16	0		
* Care must be taken to ensure that the size of this enclosure can accommodate the cable bending radius.			

Cable Gland Entry Matrix		
Entry Size	Side A-C	Side B-D
M16	6	0
M20	4	0
M25	3	0
M32	0	0
M40	0	0

Drilling Envelope Size	
Side A-C	55 x 160mm
Side B-D	52 x 19mm

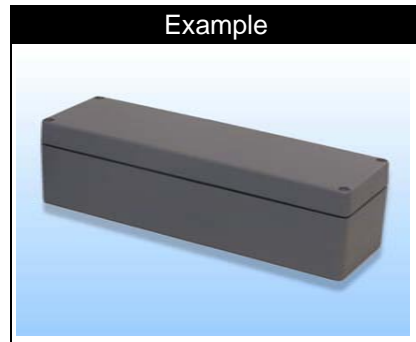
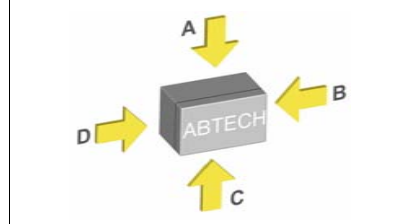

BPG 5 / BPGC 5 Drawing

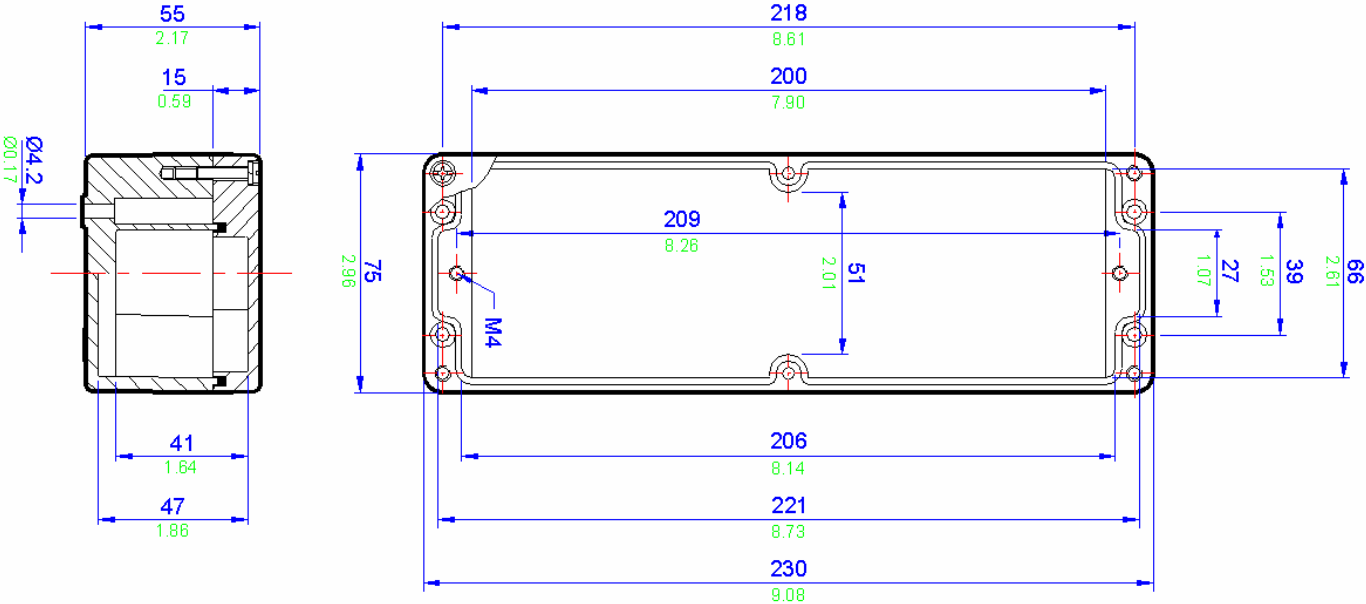

All blue dimensions in mm, all green dimensions in decimal inches (drawing not to scale)

BPG 5 / BPGC 5 Specifications	
Width	230mm
Length	75mm
Depth	55mm
Material	BPG5 - Glass Reinforced Polyester (RAL7001 grey)
	BPGC5 - Carbon Loaded Glass Reinforced Polyester (Black)
Weight	529g
IP Rating	66/67
Temperature	-40° to 80° C (-40°F to +176°F) (standard neoprene gasket)
	-70° to 130° C (-94°F to +266°F) (silicone gasket)
Certification	ATEX EEx'e' BS EN 50019 (Zone 1 & 2)
	ATEX EEx'nA' BS EN 50021 (Zone 2)
	NEMA 4X (CSA & UL) (class 1 division 2)
	GOST-R Ex'e' (Zone 1 & 2)
Power Rating	9.260W

Terminal Populations			
Maximum Number of Rows			1
Weidmuller		Wago	
BK4 (4 way)	0	280-992	0
BK6 (6 way)	4	280-999	0
BK12 (12 way)	2	281-691	0
MK6/3	4	281-992	0
MK6/4	4	281-993	0
MK6/6	2	282-691	0
SAK2.5	0	284-691	0
SAK4	0	283-691	0
SAK6N	0	285-691	0
SAK10	0	280-998	0
SAK16	0	281-998	0
SAK35	0	264-120	32
Entrelec		264-220	19
MA2.5/5	0	264-132 (2)	6
M4/6	0	264-134 (4)	4
M6/8	0	262-132 (2)	6
M10/10	0	262-134 (4)	4
M16/12	0		
M35/16	0		

Cable Gland Entry Matrix		
Entry Size	Side A-C	Side B-D
M16	0	0
M20	0	0
M25	0	0
M32	0	0
M40	0	0

Drilling Envelope Size	
Side A-C	90 x 30mm
Side B-D	23 x 28mm

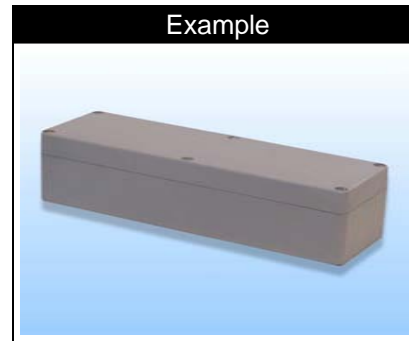
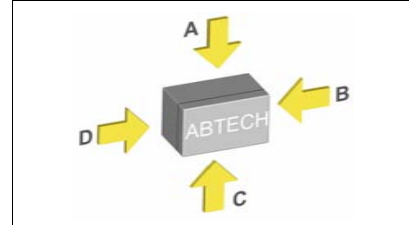

Technical 9	Others 8	ZP Range 7	Fire Rated 6	High Voltage 5	ZAG Range 4	BPGA Range 3	BPG Range 2	SX Range 1
----------------	-------------	---------------	-----------------	-------------------	----------------	-----------------	----------------	---------------

BPG 6 / BPGC 6 Specifications	
Width	122mm
Length	120mm
Depth	90mm
Material	BPG6 - Glass Reinforced Polyester (RAL7001 grey)
	BPGC6 - Carbon Loaded Glass Reinforced Polyester (Black)
Weight	750g
IP Rating	66/67
Temperature	-40° to 80° C (-40°F to +176°F) (standard neoprene gasket)
	-70° to 130° C (-94°F to +266°F) (silicone gasket)
Certification	ATEX EEEx'e' BS EN 50019 (Zone 1 & 2)
	ATEX EEEx'nA' BS EN 50021 (Zone 2)
	NEMA 4X (CSA & UL) (class 1 division 2)
	GOST-R Ex'e' (Zone 1 & 2)
Power Rating	9.378W

Terminal Populations			
Maximum Number of Rows			1
Weidmuller		Wago	
BK4 (4 way)	2	280-992	15
BK6 (6 way)	2	280-999	15
BK12 (12 way)	1	281-691	13
MK6/3	1	281-992	13
MK6/4	1	281-993	13
MK6/6	1	282-691	10
SAK2.5	14	284-691	8
SAK4	13	283-691	6
SAK6N	10	285-691	0
SAK10 *	8	280-998	15
SAK16 *	7	281-998	13
SAK35 *	5	264-120	13
Entelec		264-220	8
MA2.5/5	17	264-132 (2)	3
M4/6	14	264-134 (4)	2
M6/8	8	262-132 (2)	3
M10/10 *	8	262-134 (4)	2
M16/12 *	7		
M35/16 *	5		
* Care must be taken to ensure that the size of this enclosure can accommodate the cable bending radius.			

Cable Gland Entry Matrix		
Entry Size	Side A-C	Side B-D
M16	2	1
M20	1	1
M25	1	1
M32	1	0
M40	0	0

Drilling Envelope Size	
Side A-C	75 x 60mm
Side B-D	54 x 53mm

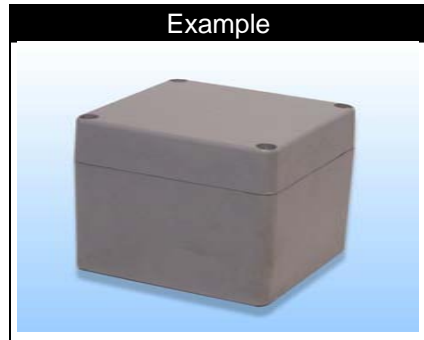
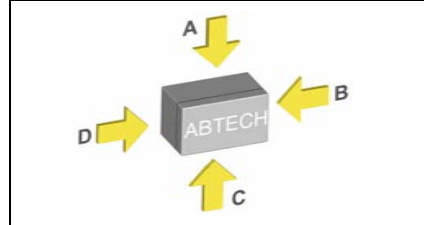

Technical	Others	ZIP Range	Fire Rated	High Voltage	ZAG Range	BPGA Range	BPG Range	SX Range
9	8	7	6	5	4	3	2	1

BPG 7 / BPGC 7 Drawing

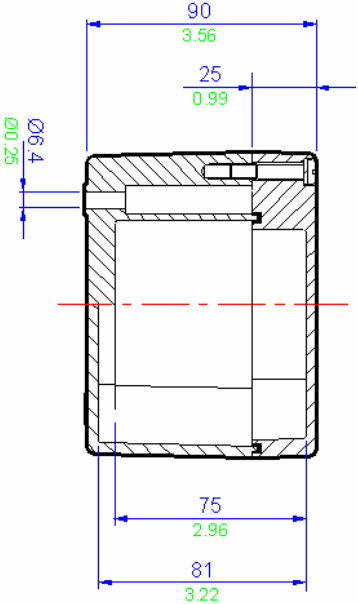
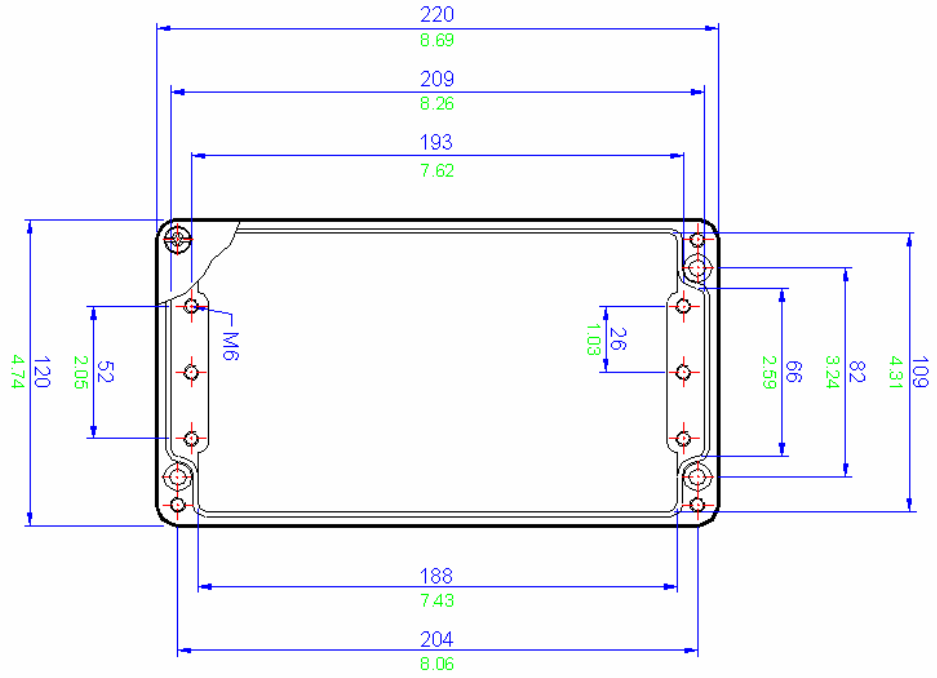

All blue dimensions in mm, all green dimensions in decimal inches (drawing not to scale)

BPG 7 / BPGC 7 Specifications	
Width	220mm
Length	120mm
Depth	90mm
Material	BPG7 - Glass Reinforced Polyester (RAL7001 grey)
	BPGC7 - Carbon Loaded Glass Reinforced Polyester (Black)
Weight	1060g
IP Rating	66/67
Temperature	-40° to 80° C (-40°F to +176°F) (standard neoprene gasket)
	-70° to 130° C (-94°F to +266°F) (silicone gasket)
Certification	ATEX EEx'e' BS EN 50019 (Zone 1 & 2)
	ATEX EEx'nA' BS EN 50021 (Zone 2)
	NEMA 4X (CSA & UL) (class 1 division 2)
	GOST-R Ex'e' (Zone 1 & 2)
Power Rating	10.500W

Terminal Populations			
Maximum Number of Rows			1
Weidmuller		Wago	
BK4 (4 way)	5	280-992	34
BK6 (6 way)	3	280-999 *	34
BK12 (12 way)	2	281-691	29
MK6/3	4	281-992	29
MK6/4	4	281-993 *	29
MK6/6	2	282-691	22
SAK2.5	30	284-691 *	18
SAK4	28	283-691 *	15
SAK6N	22	285-691	0
SAK10 *	18	280-998	34
SAK16 *	15	281-998	29
SAK35 *	11	264-120	30
Entrelec		264-220	18
MA2.5/5	36	264-132 (2)	6
M4/6	30	264-134 (4)	4
M6/8	22	262-132 (2)	6
M10/10 *	18	262-134 (4)	4
M16/12 *	15		
M35/16 *	11		

* Care must be taken to ensure that the size of this enclosure can accommodate the cable bending radius.

Cable Gland Entry Matrix		
Entry Size	Side A-C	Side B-D
M16	10	1
M20	4	1
M25	3	1
M32	3	0
M40	0	0

Drilling Envelope Size	
Side A-C	180 x 60mm
Side B-D	56 x 53mm

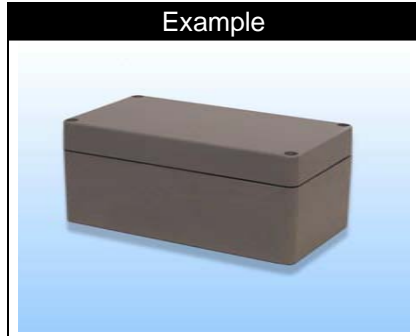
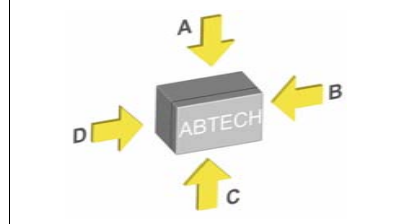

Technical 9	Others 8	ZP Range 7	Fire Rated 6	High Voltage 5	ZAG Range 4	BPGA Range 3	BPG Range 2	SX Range 1
----------------	-------------	---------------	-----------------	-------------------	----------------	-----------------	----------------	---------------

BPG 8 / BPGC 8 Specifications	
Width	160mm
Length	160mm
Depth	90mm
Material	BPG8 - Glass Reinforced Polyester (RAL7001 grey)
	BPGC8 - Carbon Loaded Glass Reinforced Polyester (Black)
Weight	1060g
IP Rating	66/67
Temperature	-40° to 80° C (-40°F to +176°F) (standard neoprene gasket)
	-70° to 130° C (-94°F to +266°F) (silicone gasket)
Certification	ATEX EEx'e' BS EN 50019 (Zone 1 & 2)
	ATEX EEx'nA' BS EN 50021 (Zone 2)
	NEMA 4X (CSA & UL) (class 1 division 2)
	GOST-R Ex'e' (Zone 1 & 2)
Power Rating	10.348W

Terminal Populations			
Maximum Number of Rows			1
Weidmuller		Wago	
BK4 (4 way)	3	280-992	22
BK6 (6 way)	2	280-999	22
BK12 (12 way)	1	281-691	19
MK6/3	2	281-992	19
MK6/4	2	281-993	19
MK6/6	1	282-691	15
SAK2.5	20	284-691 *	12
SAK4	19	283-691 *	10
SAK6N	15	285-691	0
SAK10 *	12	280-998	22
SAK16 *	10	281-998	19
SAK35 *	7	264-120	20
Entrelec		264-220	12
MA2.5/5	24	264-132 (2)	4
M4/6	20	264-134 (4)	3
M6/8	15	262-132 (2)	4
M10/10 *	12	262-134 (4)	2
M16/12 *	10		
M35/16 *	7		
* Care must be taken to ensure that the size of this enclosure can accommodate the cable bending radius.			

Cable Gland Entry Matrix		
Entry Size	Side A-C	Side B-D
M16	6	2
M20	2	2
M25	2	1
M32	1	1
M40	0	0

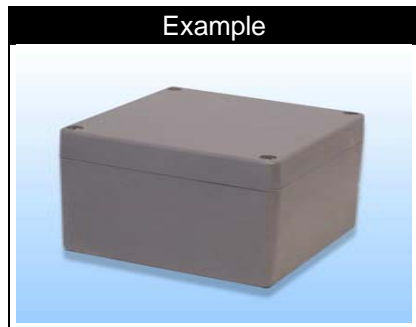
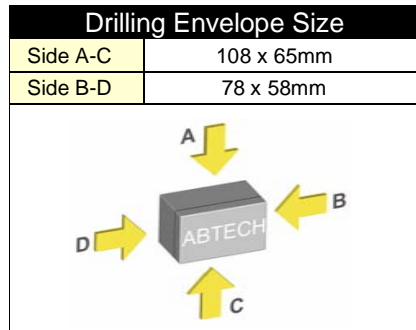

Technical 9	Others 8	ZP Range 7	Fire Rated 6	High Voltage 5	ZAG Range 4	BPGA Range 3	BPG Range 2	SX Range 1
----------------	-------------	---------------	-----------------	-------------------	----------------	-----------------	----------------	---------------

BPG 9 / BPGC 9 Specifications	
Width	260mm
Length	160mm
Depth	90mm
Material	BPG9 - Glass Reinforced Polyester (RAL7001 grey)
	BPGC9 - Carbon Loaded Glass Reinforced Polyester (Black)
Weight	1170g
IP Rating	66/67
Temperature	-40° to 80° C (-40°F to +176°F) (standard neoprene gasket)
	-70° to 130° C (-94°F to +266°F) (silicone gasket)
Certification	ATEX EEx'e' BS EN 50019 (Zone 1 & 2)
	ATEX EEx'nA' BS EN 50021 (Zone 2)
	NEMA 4X (CSA & UL) (class 1 division 2)
	GOST-R Ex'e' (Zone 1 & 2)
Power Rating	11.933W

Terminal Populations			
Maximum Number of Rows			1
Weidmuller		Wago	
BK4 (4 way)	6	280-992	40
BK6 (6 way)	4	280-999	40
BK12 (12 way)	2	281-691	34
MK6/3	4	281-992	34
MK6/4	4	281-993	34
MK6/6	3	282-691	27
SAK2.5	36	284-691 *	21
SAK4	34	283-691 *	18
SAK6N	27	285-691	0
SAK10 *	22	280-998	40
SAK16 *	18	281-998	34
SAK35 *	14	264-120	36
Entrelec		264-220	21
MA2.5/5	43	264-132 (2)	7
M4/6	36	264-134 (4)	5
M6/8	27	262-132 (2)	7
M10/10 *	22	262-134 (4)	5
M16/12 *	18		
M35/16 *	14		
* Care must be taken to ensure that the size of this enclosure can accommodate the cable bending radius.			

Cable Gland Entry Matrix		
Entry Size	Side A-C	Side B-D
M16	12	4
M20	6	2
M25	4	1
M32	3	1
M40	0	0

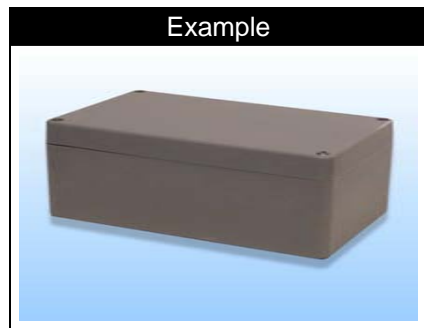
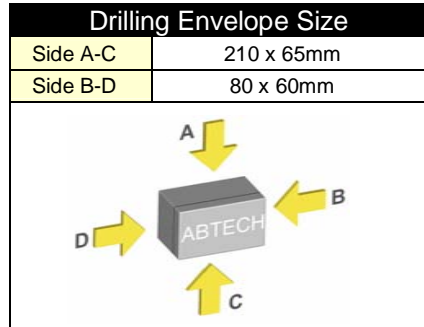

Technical	Others	ZIP Range	Fire Rated	High Voltage	ZAG Range	BPGA Range	BPG Range	SX Range
9	8	7	6	5	4	3	2	1

BPG 10 / BPGC 10 Drawing

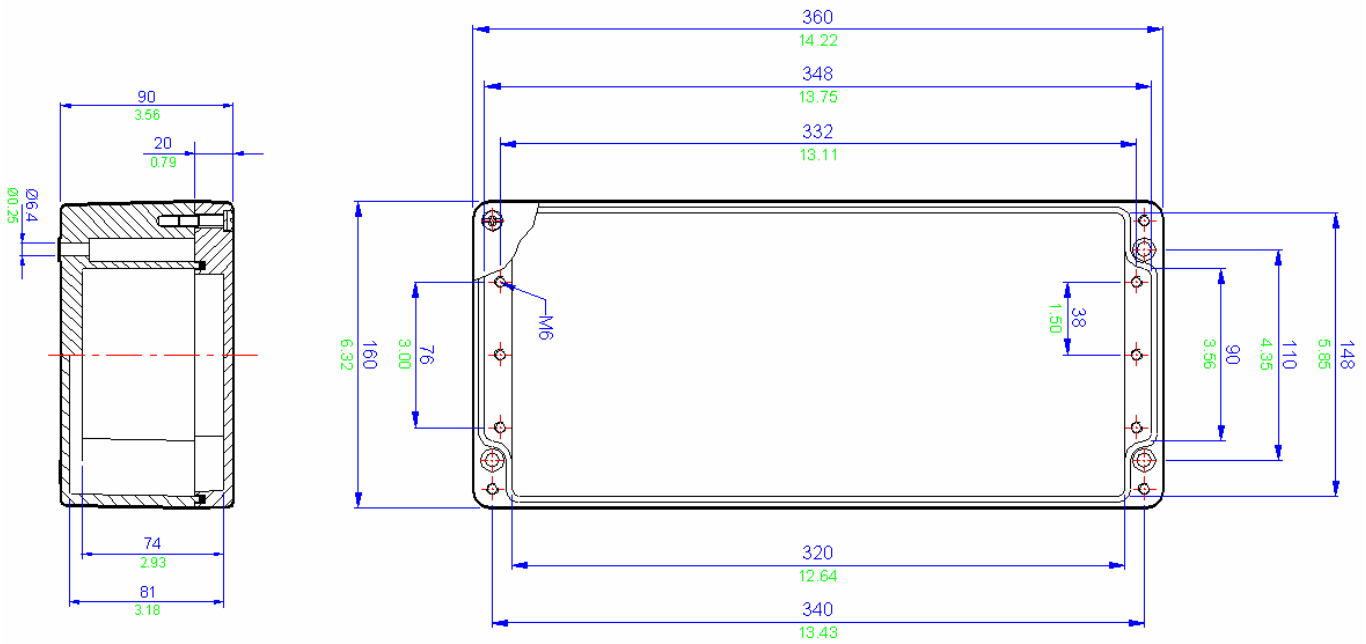

All blue dimensions in mm, all green dimensions in decimal inches (drawing not to scale)

BPG 10 / BPGC 10 Specifications	
Width	360mm
Length	160mm
Depth	90mm
Material	BPG10 - Glass Reinforced Polyester (RAL7001 grey)
	BPGC10 - Carbon Loaded Glass Reinforced Polyester (Black)
Weight	2150g
IP Rating	66/67
Temperature	-40° to 80° C (-40°F to +176°F) (standard neoprene gasket)
	-70° to 130° C (-94°F to +266°F) (silicone gasket)
Certification	ATEX EEx'e' BS EN 50019 (Zone 1 & 2)
	ATEX EEx'nA' BS EN 50021 (Zone 2)
	NEMA 4X (CSA & UL) (class 1 division 2)
	GOST-R Ex'e' (Zone 1 & 2)
Power Rating	13.793W

Terminal Populations			
Maximum Number of Rows			1
Weidmuller		Wago	
BK4 (4 way)	9	280-992	58
BK6 (6 way)	6	280-999	58
BK12 (12 way)	3	281-691	50
MK6/3	6	281-992	50
MK6/4	6	281-993	50
MK6/6	4	282-691	39
SAK2.5	52	284-691 *	31
SAK4	48	283-691 *	26
SAK6N	40	285-691	0
SAK10 *	32	280-998	58
SAK16 *	26	281-998	50
SAK35 *	20	264-120	52
Entrelec		264-220	31
MA2.5/5	63	264-132 (2)	11
M4/6	52	264-134 (4)	7
M6/8	40	262-132 (2)	10
M10/10 *	32	262-134 (4)	7
M16/12 *	26		
M35/16 *	20		

* Care must be taken to ensure that the size of this enclosure can accommodate the cable bending radius.

Cable Gland Entry Matrix		
Entry Size	Side A-C	Side B-D
M16	18	4
M20	8	2
M25	6	1
M32	5	1
M40	0	0

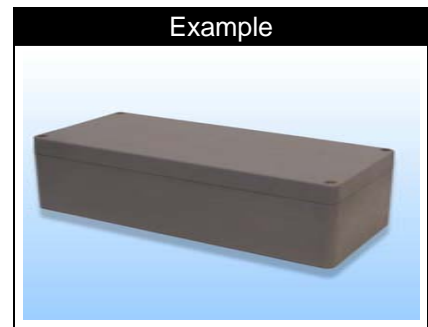
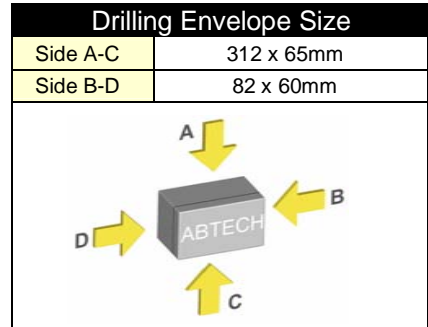

Technical	Others	ZP Range	Fire Rated	High Voltage	ZAG Range	BPGA Range	BPG Range	SX Range
9	8	7	6	5	4	3	2	1

BPG 11 / BPGC 11 Drawing

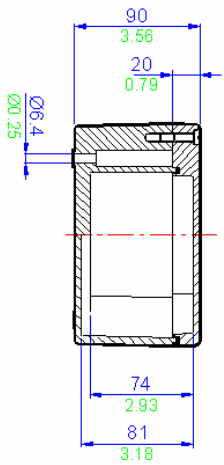
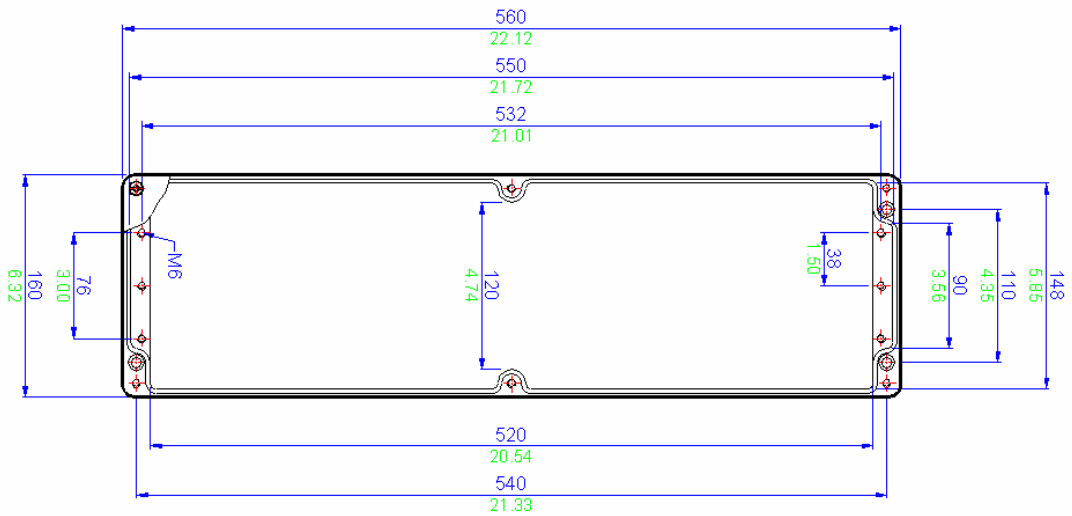

All blue dimensions in mm, all green dimensions in decimal inches (drawing not to scale)

BPG 11 / BPGC 11 Specifications	
Width	560mm
Length	160mm
Depth	90mm
Material	BPG11 - Glass Reinforced Polyester (RAL7001 grey)
	BPGC11 - Carbon Loaded Glass Reinforced Polyester (Black)
Weight	3200g
IP Rating	66/67
Temperature	-40° to 80° C (-40°F to +176°F) (standard neoprene gasket)
	-70° to 130° C (-94°F to +266°F) (silicone gasket)
Certification	ATEX EEx'e' BS EN 50019 (Zone 1 & 2)
	ATEX EEx'nA' BS EN 50021 (Zone 2)
	NEMA 4X (CSA & UL) (class 1 division 2)
	GOST-R Ex'e' (Zone 1 & 2)
Power Rating	18.338W

Terminal Populations				
Maximum Number of Rows			1	
Weidmuller		Wago		
BK4 (4 way)	14	280-992	96	
BK6 (6 way)	10	280-999	96	
BK12 (12way)	5	281-691	82	
MK6/3	11	281-992	82	
MK6/4	11	281-993	82	
MK6/6	7	282-691	63	
SAK2.5	85	284-691 *	51	
SAK4	78	283-691 *	42	
SAK6N	64	285-691	0	
SAK10 *	51	280-998	96	
SAK16 *	43	281-998	82	
SAK35 *	32	264-120	85	
Entelec		264-220	51	
MA2.5/5	101	264-132 (2)	18	
M4/6	85	264-134 (4)	12	
M6/8	64	262-132 (2)	17	
M10/10 *	51	262-134 (4)	12	
M16/12 *	43			
M35/16 *	32			
* Care must be taken to ensure that the size of this enclosure can accommodate the cable bending radius.				

Cable Gland Entry Matrix		
Entry Size	Side A-C	Side B-D
M16	28	4
M20	12	2
M25	10	1
M32	8	1
M40	0	0

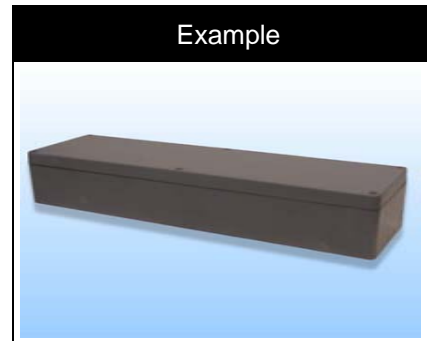
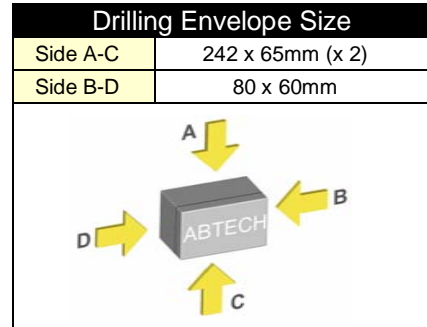

Technical 9	Others 8	ZP Range 7	Fire Rated 6	High Voltage 5	ZAG Range 4	BPGA Range 3	BPG Range 2	SX Range 1
----------------	-------------	---------------	-----------------	-------------------	----------------	-----------------	----------------	---------------

BPG 12 / BPGC 12 Drawing

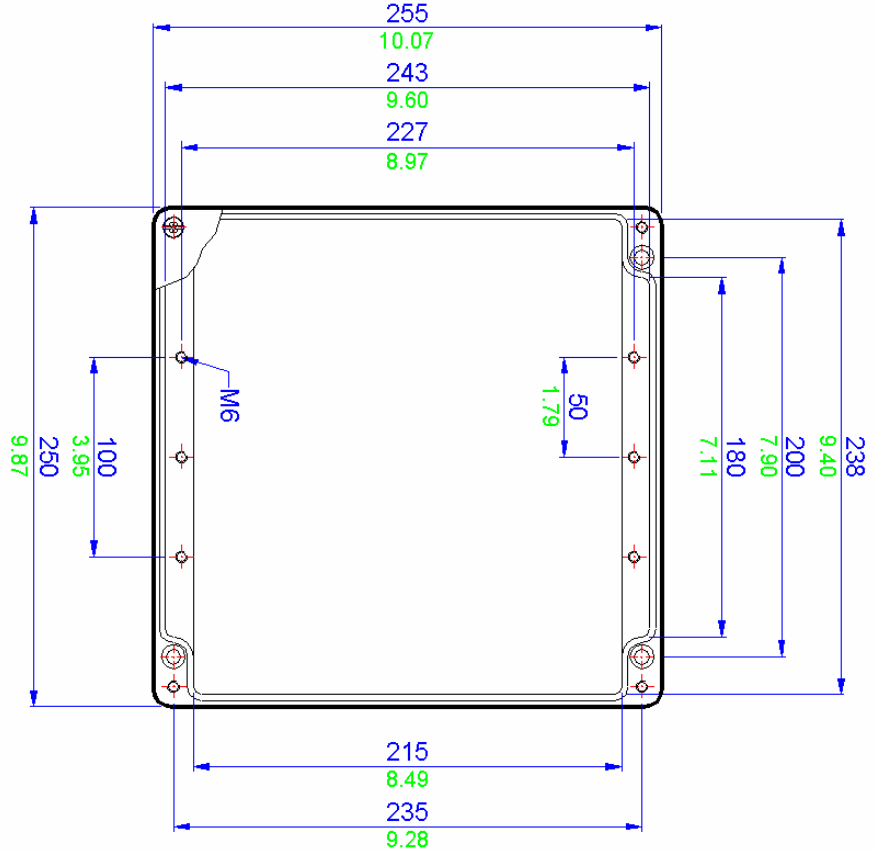
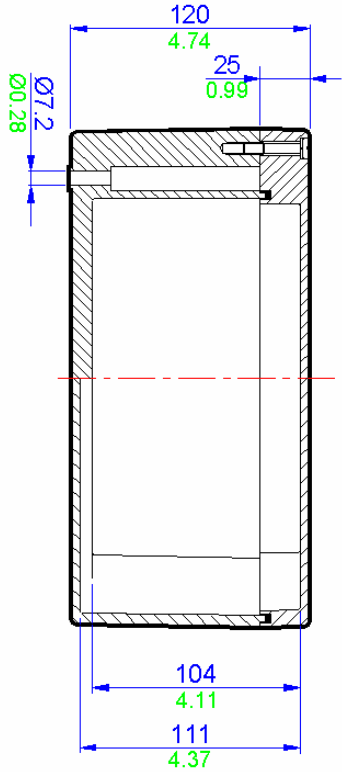

All blue dimensions in mm, all green dimensions in decimal inches (drawing not to scale)

BPG 12 / BPGC 12 Specifications	
Width	255mm
Length	250mm
Depth	120mm
Material	BPG12 - Glass Reinforced Polyester (RAL7001 grey)
	BPGC12 - Carbon Loaded Glass Reinforced Polyester (Black)
Weight	3200g
IP Rating	66/67
Temperature	-40° to 80° C (-40°F to +176°F) (standard neoprene gasket)
	-70° to 130° C (-94°F to +266°F) (silicone gasket)
Certification	ATEX EEx'e' BS EN 50019 (Zone 1 & 2)
	ATEX EEx'nA' BS EN 50021 (Zone 2)
	NEMA 4X (CSA & UL) (class 1 division 2)
	GOST-R Ex'e' (Zone 1 & 2)
Power Rating	15.474W

Terminal Populations			
Maximum Number of Rows		2	
Weidmuller		Wago	
BK4 (4 way)	12	280-992	78
BK6 (6 way)	8	280-999	78
BK12 (12 way)	4	281-691	66
MK6/3	8	281-992	66
MK6/4	8	281-993	66
MK6/6	6	282-691	52
SAK2.5	70	284-691 *	42
SAK4	66	283-691 *	17
SAK6N	54	285-691	12
SAK10 *	42	280-998	78
SAK16 *	36	281-998	66
SAK35 *	26	264-120	70
Entrelec		264-220	42
MA2.5/5	84	264-132 (2)	14
M4/6	70	264-134 (4)	10
M6/8	54	262-132 (2)	14
M10/10 *	42	262-134 (4)	8
M16/12 *	36		
M35/16 *	26		
* Care must be taken to ensure that the size of this enclosure can accommodate the cable bending radius.			

Cable Gland Entry Matrix		
Entry Size	Side A-C	Side B-D
M16	15	12
M20	10	8
M25	6	4
M32	3	2
M40	3	2

Drilling Envelope Size	
Side A-C	205 x 90mm
Side B-D	170 x 85mm

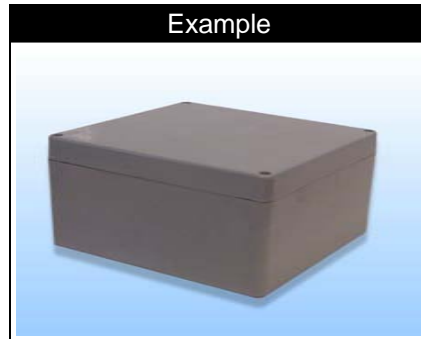
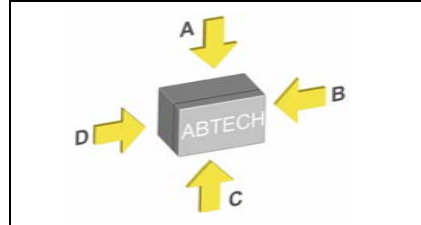

Technical 9	Others 8	ZP Range 7	Fire Rated 6	High Voltage 5	ZAG Range 4	BPGA Range 3	BPG Range 2	SX Range 1
----------------	-------------	---------------	-----------------	-------------------	----------------	-----------------	----------------	---------------

BPG 13 / BPGC 13 Drawing

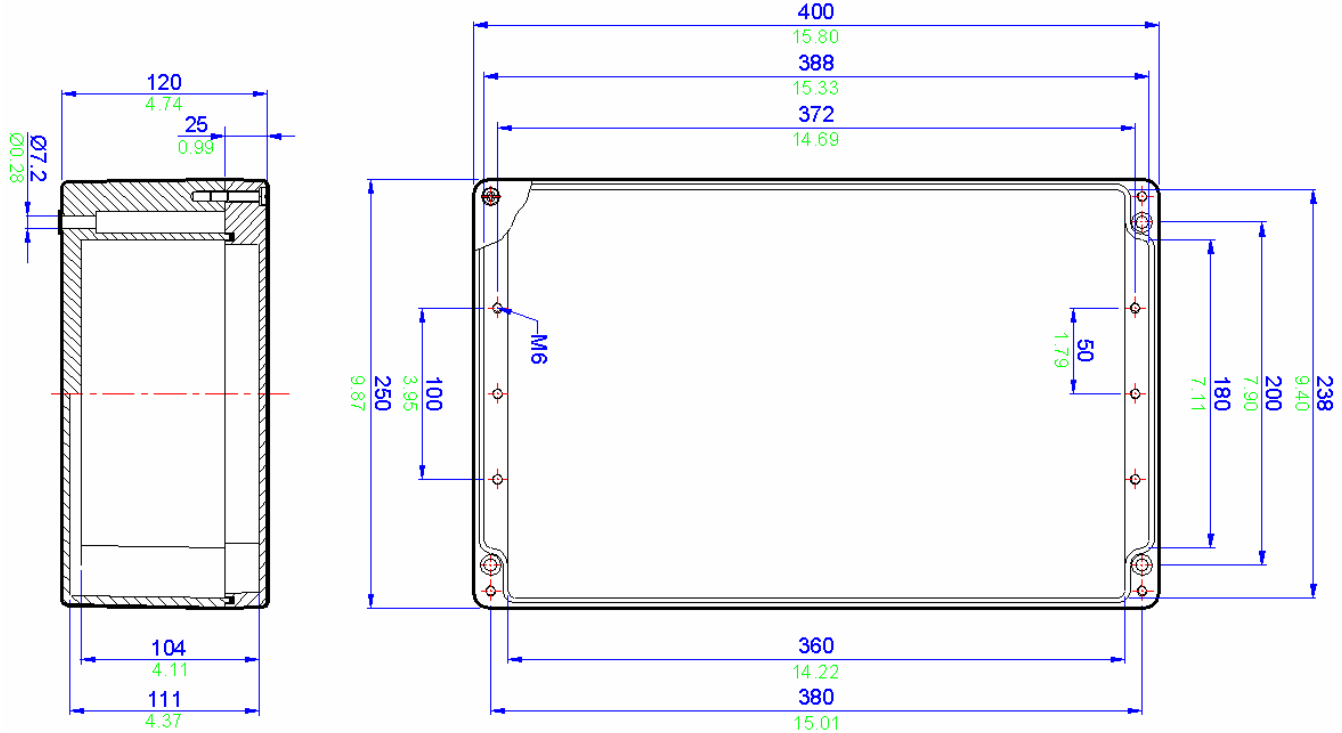

All blue dimensions in mm, all green dimensions in decimal inches (drawing not to scale)

BPG 13 / BPGC 13 Specifications	
Width	400mm
Length	250mm
Depth	120mm
Material	BPG13 - Glass Reinforced Polyester (RAL7001 grey)
	BPGC13 - Carbon Loaded Glass Reinforced Polyester (Black)
Weight	3650g
IP Rating	66/67
Temperature	-40° to 80° C (-40°F to +176°F) (standard neoprene gasket)
	-70° to 130° C (-94°F to +266°F) (silicone gasket)
Certification	ATEX EEx'e' BS EN 50019 (Zone 1 & 2)
	ATEX EEx'nA' BS EN 50021 (Zone 2)
	NEMA 4X (CSA & UL) (class 1 division 2)
	GOST-R Ex'e' (Zone 1 & 2)
Power Rating	20.867W

Terminal Populations			
Maximum Number of Rows			2
Weidmuller		Wago	
BK4 (4 way)	20	280-992	132
BK6 (6 way)	14	280-999	132
BK12 (12 way)	6	281-691	114
MK6/3	14	281-992 *	114
MK6/4	14	281-993	114
MK6/6	10	282-691	88
SAK2.5	118	284-691 *	70
SAK4	108	283-691 *	29
SAK6N	88	285-691	20
SAK10 *	72	280-998	132
SAK16 *	60	281-998	114
SAK35 *	44	264-120	118
Entelec		264-220	70
MA2.5/5	140	264-132 (2)	24
M4/6	118	264-134 (4)	16
M6/8	88	262-132 (2)	24
M10/10 *	72	262-134 (4)	16
M16/12 *	60		
M35/16 *	44		

* Care must be taken to ensure that the size of this enclosure can accommodate the cable bending radius.

Cable Gland Entry Matrix		
Entry Size	Side A-C	Side B-D
M16	30	12
M20	16	8
M25	14	4
M32	6	2
M40	5	2

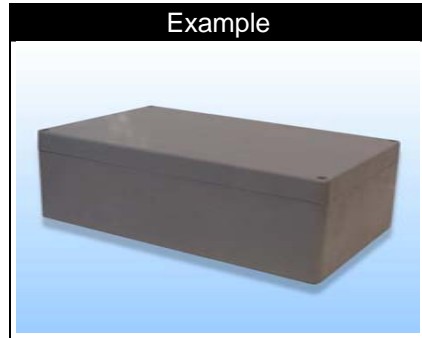
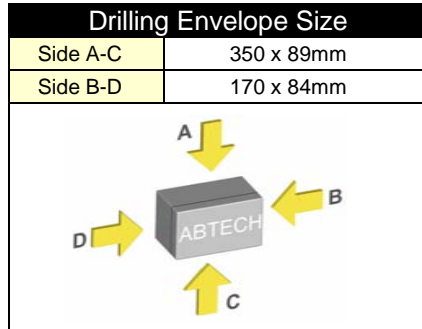

Technical 9	Others 8	ZP Range 7	Fire Rated 6	High Voltage 5	ZAG Range 4	BPGA Range 3	BPG Range 2	SX Range 1
----------------	-------------	---------------	-----------------	-------------------	----------------	-----------------	----------------	---------------

BPG 13.5 / BPGC 13.5 Drawing

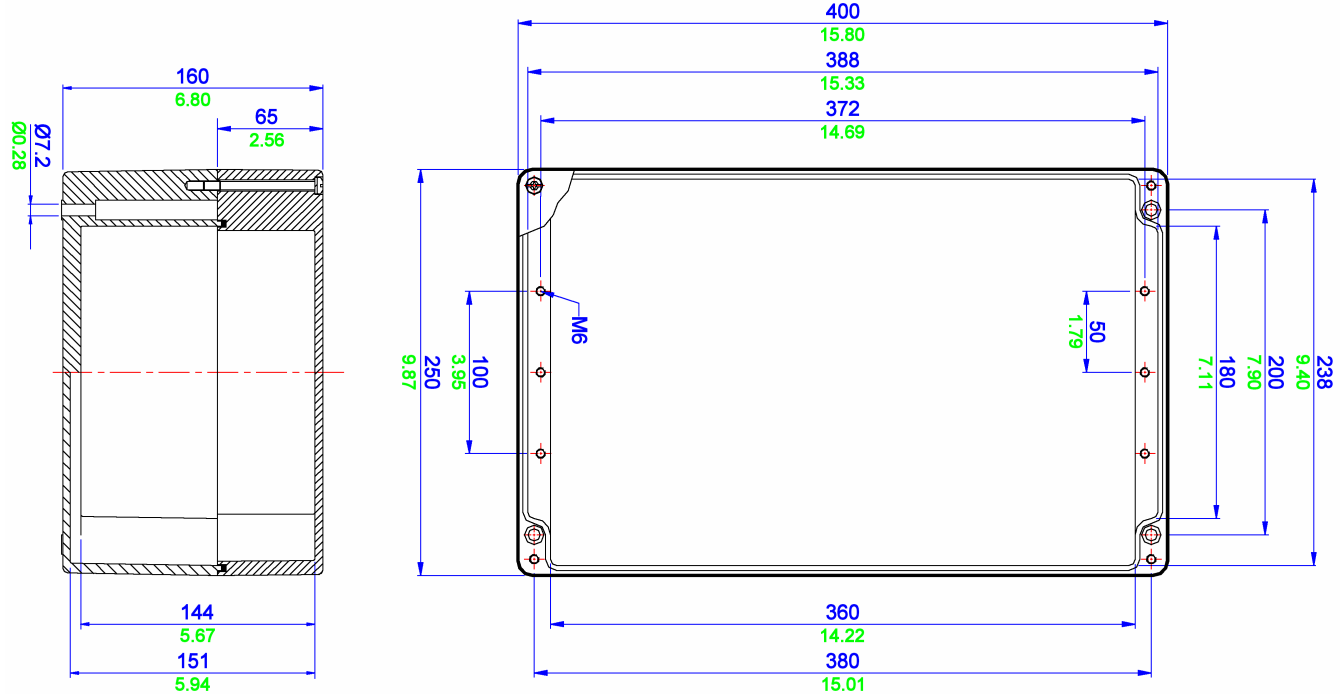

All blue dimensions in mm, all green dimensions in decimal inches (drawing not to scale)

BPG / C 13.5 Specifications	
Width	400mm
Length	250mm
Depth	160mm
Material	BPG13.5 - Glass Reinforced Polyester (RAL7001 grey)
	BPGC13.5 - Carbon Loaded Glass Reinforced Polyester (Black)
Weight	4872g
IP Rating	66/67
Temperature	-40° to 80° C (-40°F to +176°F) (standard neoprene gasket)
	-70° to 130° C (-94°F to +266°F) (silicone gasket)
Certification	ATEX EEx'e' BS EN 50019 (Zone 1 & 2)
	ATEX EEx'nA' BS EN 50021 (Zone 2)
	NEMA 4X (CSA & UL) (class 1 division 2)
	GOST-R Ex'e' (Zone 1 & 2)
Power Rating	20.867W

Terminal Populations			
Maximum Number of Rows			2
Weidmuller		Wago	
BK4 (4 way)	20	280-992	132
BK6 (6 way)	14	280-999	132
BK12 (12 way)	6	281-691	114
MK6/3	14	281-992 *	114
MK6/4	14	281-993	114
MK6/6	10	282-691	88
SAK2.5	118	284-691 *	70
SAK4	108	283-691 *	29
SAK6N	88	285-691	20
SAK10 *	72	280-998	132
SAK16 *	60	281-998	114
SAK35 *	44	264-120	118
Entelec		264-220	70
MA2.5/5	140	264-132 (2)	24
M4/6	118	264-134 (4)	16
M6/8	88	262-132 (2)	24
M10/10 *	72	262-134 (4)	16
M16/12 *	60		
M35/16 *	44		

* Care must be taken to ensure that the size of this enclosure can accommodate the cable bending radius.

Cable Gland Entry Matrix		
Entry Size	Side A-C	Side B-D
M16	30	12
M20	16	8
M25	14	4
M32	6	2
M40	5	2

Drilling Envelope Size	
Side A-C	350 x 89mm
Side B-D	170 x 84mm

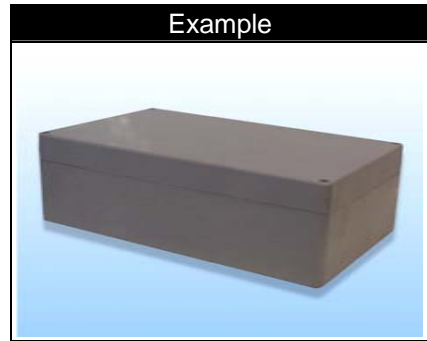
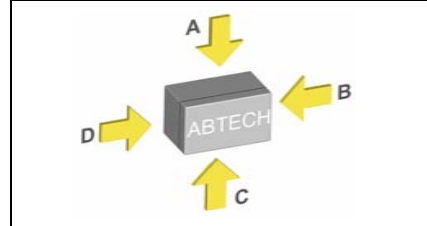

Technical 9	Others 8	ZP Range 7	Fire Rated 6	High Voltage 5	ZAG Range 4	BPGA Range 3	BPG Range 2	SX Range 1
----------------	-------------	---------------	-----------------	-------------------	----------------	-----------------	----------------	---------------

BPG 14 / BPGC 14 Drawing

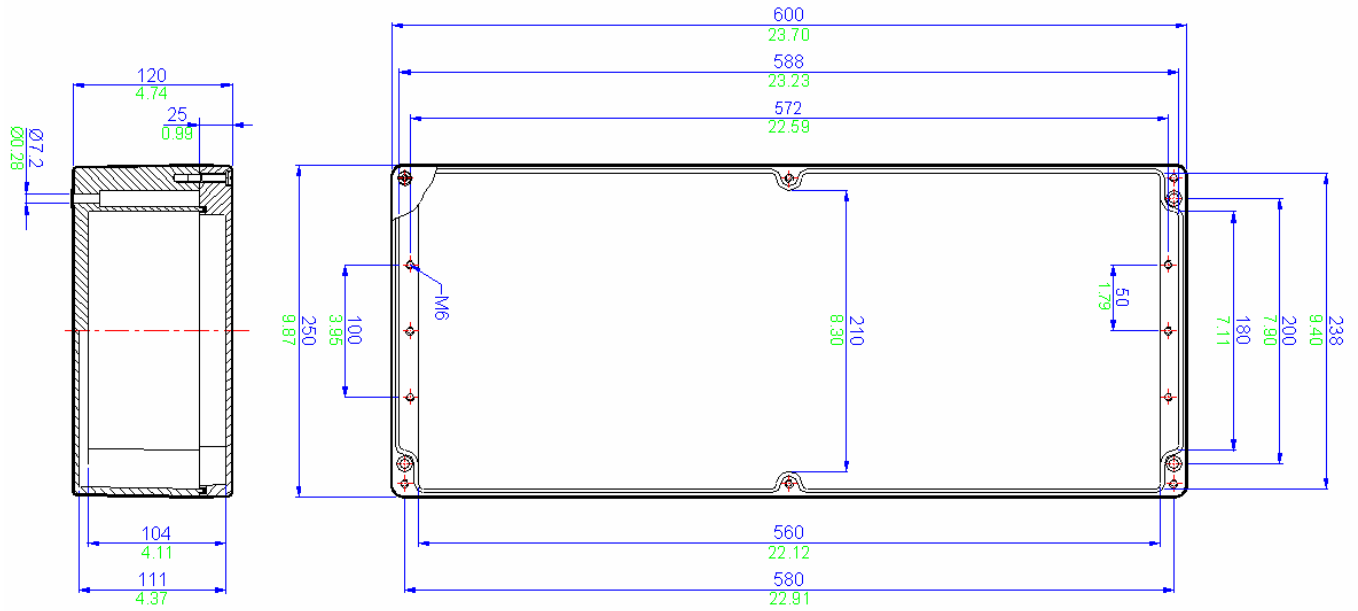

All blue dimensions in mm, all green dimensions in decimal inches (drawing not to scale)

BPG 14 / BPGC 14 Specifications	
Width	600mm
Length	250mm
Depth	120mm
Material	BPG14 - Glass Reinforced Polyester (RAL7001 grey)
	BPGC14 - Carbon Loaded Glass Reinforced Polyester (Black)
Weight	5235g
IP Rating	66/67
Temperature	-40° to 80° C (-40°F to +176°F) (standard neoprene gasket)
	-70° to 130° C (-94°F to +266°F) (silicone gasket)
Certification	ATEX EEx'e' BS EN 50019 (Zone 1 & 2)
	ATEX EEx'nA' BS EN 50021 (Zone 2)
	NEMA 4X (CSA & UL) (class 1 division 2)
	GOST-R Ex'e' (Zone 1 & 2)
Power Rating	30.384W

Terminal Populations			
Maximum Number of Rows			2
Weidmuller		Wago	
BK4 (4 way)	30	280-992	132
BK6 (6 way)	22	280-999	132
BK12 (12 way)	12	281-691	114
MK6/3	22	281-992 *	114
MK6/4	22	281-993	114
MK6/6	14	282-691	88
SAK2.5	182	284-691 *	70
SAK4	168	283-691 *	29
SAK6N	138	285-691 *	20
SAK10 *	110	280-998	132
SAK16 *	92	281-998	114
SAK35 *	70	264-120	118
Entrelec		264-220	70
MA2.5/5	218	264-132 (2)	24
M4/6	182	264-134 (4)	16
M6/8	138	262-132 (2)	24
M10/10 *	110	262-134 (4)	16
M16/12 *	92		
M35/16 *	70		
* Care must be taken to ensure that the size of this enclosure can accommodate the cable bending radius.			

Cable Gland Entry Matrix		
Entry Size	Side A-C	Side B-D
M16	42	12
M20	24	8
M25	20	4
M32	8	2
M40	6	2

Drilling Envelope Size	
Side A-C	260 x 90mm (x 2)
Side B-D	168 x 85mm

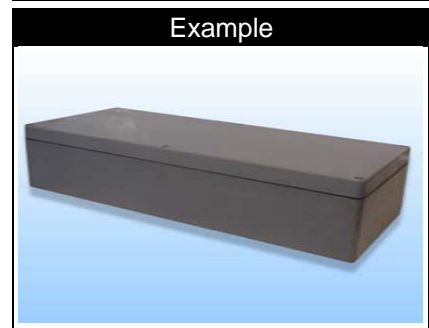
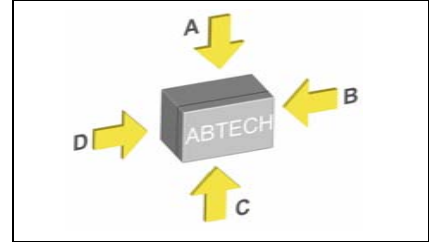

Technical 9	Others 8	ZP Range 7	Fire Rated 6	High Voltage 5	ZAG Range 4	BPGA Range 3	BPG Range 2	SX Range 1
----------------	-------------	---------------	-----------------	-------------------	----------------	-----------------	----------------	---------------

BPG 15 / BPGC 15 Drawing

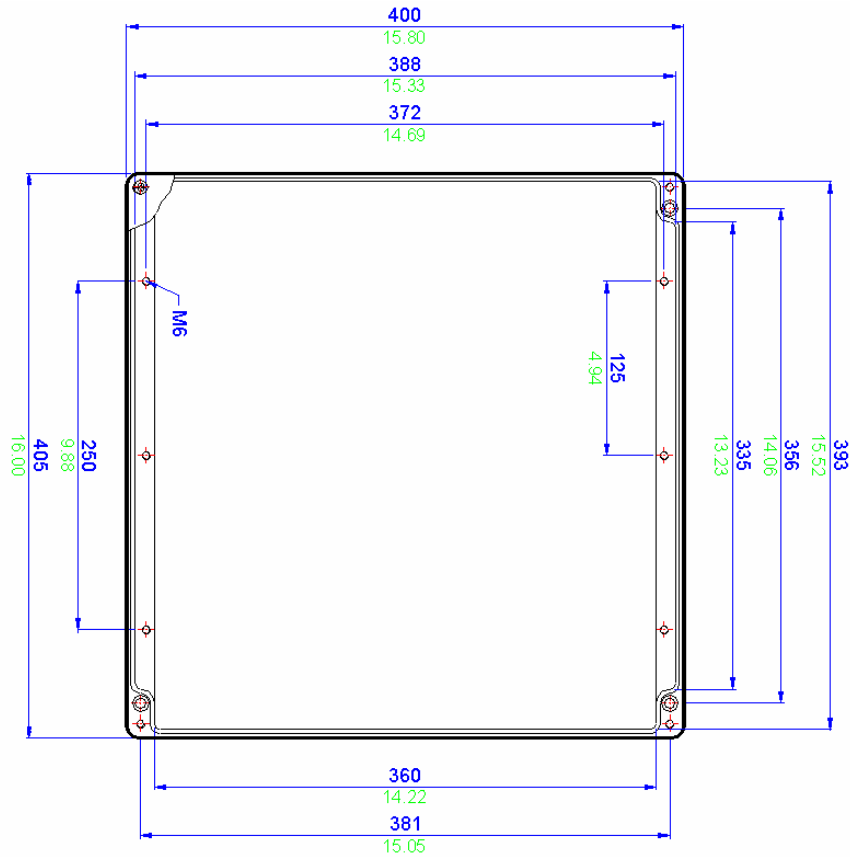
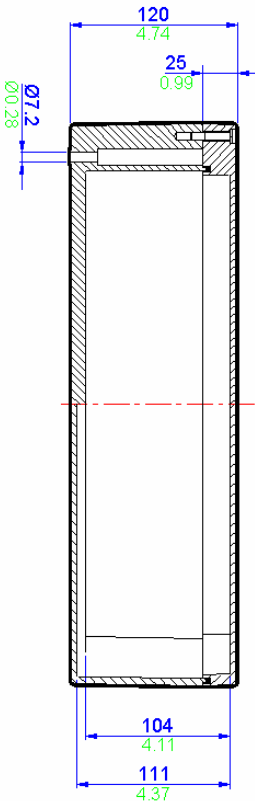

All blue dimensions in mm, all green dimensions in decimal inches (drawing not to scale)

BPG 15 / BPGC 15 Specifications	
Width	400mm
Length	405mm
Depth	120mm
Material	BPG15 - Glass Reinforced Polyester (RAL7001 grey)
	BPGC15 - Carbon Loaded Glass Reinforced Polyester (Black)
Weight	5580g
IP Rating	66/67
Temperature	-40° to 80° C (-40°F to +176°F) (standard neoprene gasket)
	-70° to 130° C (-94°F to +266°F) (silicone gasket)
Certification	ATEX EEx'e' BS EN 50019 (Zone 1 & 2)
	ATEX EEx'nA' BS EN 50021 (Zone 2)
	NEMA 4X (CSA & UL) (class 1 division 2)
	GOST-R Ex'e' (Zone 1 & 2)
Power Rating	31.350W

Terminal Populations			
Maximum Number of Rows		3	
Weidmuller		Wago	
BK4 (4 way)	30	280-992	198
BK6 (6 way)	21	280-999	198
BK12 (12 way)	9	281-691	171
MK6/3	21	281-992 *	171
MK6/4	21	281-993	171
MK6/6	15	282-691	132
SAK2.5	177	284-691 *	105
SAK4	162	283-691 *	58
SAK6N	132	285-691 *	40
SAK10 *	108	280-998	198
SAK16 *	90	281-998	171
SAK35 *	66	264-120	177
Entrelec		264-220	101
MA2.5/5	210	264-132 (2)	36
M4/6	177	264-134 (4)	24
M6/8	132	262-132 (2)	36
M10/10 *	108	262-134 (4)	24
M16/12 *	90		
M35/16 *	66		

* Care must be taken to ensure that the size of this enclosure can accommodate the cable bending radius.

Cable Gland Entry Matrix		
Entry Size	Side A-C	Side B-D
M16	30	24
M20	18	16
M25	14	10
M32	6	5
M40	5	4

Drilling Envelope Size	
Side A-C	352 x 89mm
Side B-D	327 x 84mm

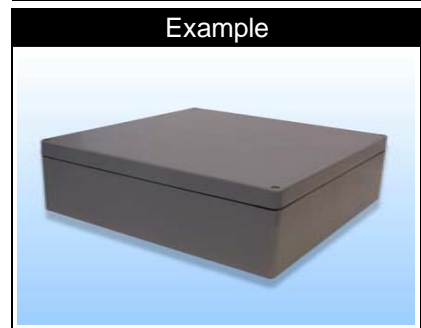
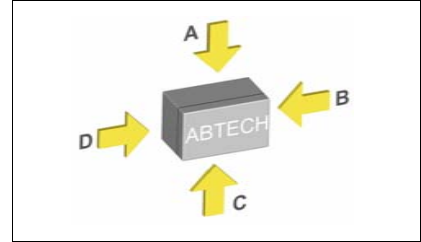

Technical 9	Others 8	ZP Range 7	Fire Rated 6	High Voltage 5	ZAG Range 4	BPGA Range 3	BPG Range 2	SX Range 1
----------------	-------------	---------------	-----------------	-------------------	----------------	-----------------	------------------------	---------------

2
BPG Range

