

- 45 Tones 3 stage Sounder
- Automatic Synchronisation
- Volume control
- IP Rating
- Operating Temperature Range -20°C to +55°C

Unit Type No. E2xS112EG

Input Voltages: DC Units 10-30V or 48V
AC Units 120V or 230V

 II 3G EEx nA nL IIC T4 (Tamb. -20°C to +55°C)

Certificate No. DEMKO 06 ATEX 0421554

Group/Category: II 3G

Zone: Zone 2

INSTALLATION

The E2xS112EG sounders must be installed in accordance with the relevant parts of the EN60079 standards or the equivalent IEC standards. *Note the units are factory set to tone 2 (800/1000Hz alternating at 2Hz) and maximum output.* If necessary the unit should be connected to a suitable power supply in a safe area to determine what tone pattern and output level is required.

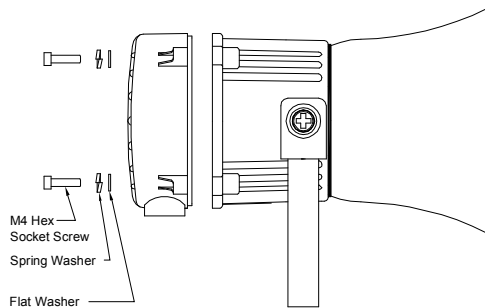

WARNING – DO NOT OPEN WHEN ENERGISED

WARNING – TO AVOID A POSSIBLE ELECTROSTATIC CHARGE ONLY CLEAN THE UNIT WITH A DAMP CLOTH

E2xS112EG DC PCB Layout

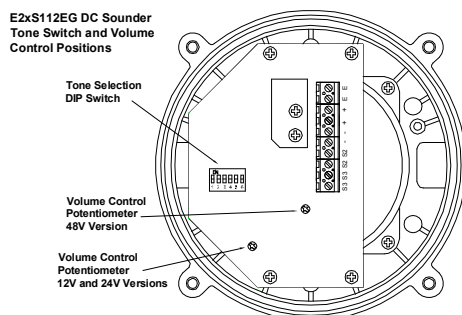

E2xS112EG AC PCB Layout

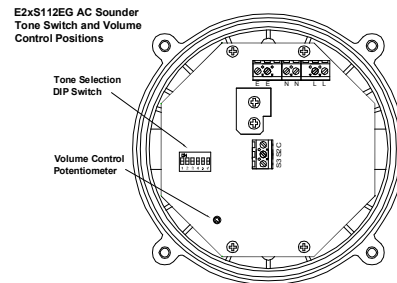

MOUNTING

The E2xS112EG sounder must be mounted using the rotating bracket as shown.

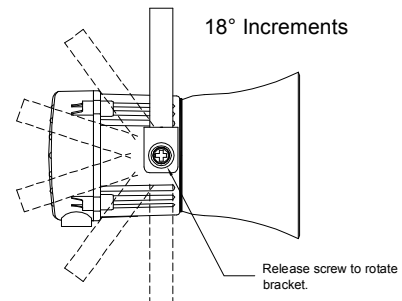

WIRING CONNECTIONS

The E2xS112EG sounder has two M20 cable entries one of which is fitted with an M20 blanking plug. This should be removed if two cable entries are required. Cable entry devices shall be used which ensure a minimum ingress protection of IP54.

The cable connections are made to the terminal blocks on the pcb assembly in the enclosure. On AC units a six way terminal block is provided for the Mains Input Supply and a separate three way terminal block is provided for selecting the second and third stage outputs if required. On DC units a ten way terminal block is provided for both the DC supply and the second and third stages.

WARNING - ALL ELECTRICAL WIRING MUST BE INSTALLED IN ACCORDANCE WITH THE RELEVANT STANDARDS AND ANY LOCAL CODES THAT MAY APPLY

AC SOUNDERS

Live	L	Common	C
Neutral	N	Stage 2	S2
Earth	E	Stage 3	S3

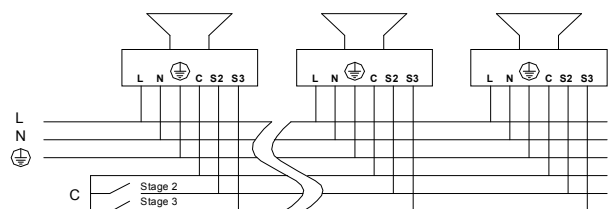

DC SOUNDERS

Positive +
 Negative -
 Stage 2 S2
 Stage 3 S3
 Earth E

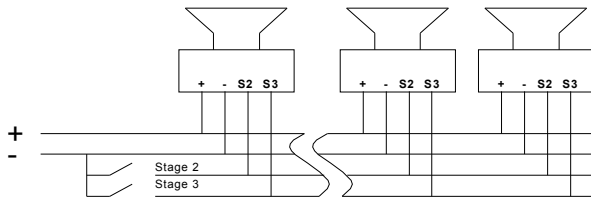

POWER SUPPLY SELECTION

It is important that a suitable power supply is used to run the sounders. The power supply selected must have the necessary capacity to provide the input current to all of the sounders connected to the system.

Unit Type	Input Voltage	Input @ 1kHz Current	Max. I/P Volts
E2xS112EG	24V DC	284mA	30V
E2xS112EG	48V DC	146mA	58V
E2xS112EG	230V AC	54mA	253V
E2xS112EG	120V AC	104mA	132V

TONE SELECTION

The E2xS112EG sounders have 45 different tones that can be selected for the first stage alarm. The sounders can then be switched to sound second and third stage alarm tones. The tones are selected by operation of a DIP switch on the pcb for both DC and AC units. The tone table opposite shows the switch positions for the 45 tones and which tones are available for the second and third stages. To operate the sounder on stage one simply connect the supply voltage to the + & - terminals for DC units and the L, N & E terminals for AC units.

The operation of the second and third stages is different for DC and AC units.

DC Units Second and Third Stage Tone Selection

To activate the second stage, remotely switch the negative supply to the S2 terminal. To activate the third stage, remotely switch the negative supply to the S3 terminal. NOTE the DC power supply to the + & - terminals must be maintained for 2nd and 3rd stages.

AC Units Second and Third Stage Tone Selection

To select the second and third stages on the E2xS112EG AC sounders the Common (C) terminal must be remotely connected to the S2 terminal for the second stage and to the S3 terminal for third stage. NOTE the AC power supply to the L, N & E terminals must be maintained for 2nd and 3rd stages.

VOLUME CONTROL

The volume on the E2xS112EG sounder can be set using the volume control (see pcb layouts on page 1). For maximum output level the potentiometer should be set to the fully clockwise position.

WARNING – HIGH VOLUME MAY CAUSE HARM TO PERSONNEL IN CLOSE PROXIMITY

TONE SELECTION TABLE

Stage 1	Frequency Description	Switch						Stage 2	Stage 3
		1	2	3	4	5	6		
1	340Hz Continuous	0	0	0	0	0	0	Tone 2	Tone 5
2	800/1000Hz @ 0.25 sec Alternating	1	0	0	0	0	0	Tone 17	Tone 5
3	500/1200Hz @ 0.3Hz sec Slow Whoop	0	1	0	0	0	0	Tone 2	Tone 5
4	800/1000Hz @ 1Hz Sweeping	1	1	0	0	0	0	Tone 6	Tone 5
5	2400Hz Continuous	0	0	1	0	0	0	Tone 3	Tone 20
6	2400/2900Hz @ 7Hz Sweeping	1	0	1	0	0	0	Tone 7	Tone 5
7	2400/2900Hz @ 1Hz Sweeping	0	1	1	0	0	0	Tone 10	Tone 5
8	500/1200/500Hz @ 0.3Hz Sweeping	1	1	1	0	0	0	Tone 2	Tone 5
9	1200/500Hz @ 1Hz - DIN PFEER P.T.A.P.	0	0	0	1	0	0	Tone 15	Tone 2
10	2400/2900Hz @ 2Hz Alternating	1	0	0	1	0	0	Tone 7	Tone 5
11	1000Hz @ 1Hz Intermittent	0	1	0	1	0	0	Tone 2	Tone 5
12	800/1000Hz @ 0.875Hz Alternating	1	1	0	1	0	0	Tone 4	Tone 5
13	2400Hz @ 1Hz Intermittent	0	0	1	1	0	0	Tone 15	Tone 5
14	800Hz 0.25 sec on, 1 sec off Intermittent	1	0	1	1	0	0	Tone 4	Tone 5
15	800Hz Continuous	0	1	1	1	0	0	Tone 2	Tone 5
16	660Hz 150mS on, 150mS off Intermittent	1	1	1	1	0	0	Tone 18	Tone 5
17	544Hz (100mS)/440 Hz (400mS) - NF S 32-001	0	0	0	0	1	0	Tone 2	Tone 27
18	660Hz 1.8 sec on, 1.8 sec off Intermittent	1	0	0	0	1	0	Tone 2	Tone 5
19	1.4KHz - 1.6KHz 1s, 1.6KHz - 1.4 KHz 0.5s - NFC48-265	0	1	0	0	1	0	Tone 2	Tone 5
20	660Hz Continuous	1	1	0	0	1	0	Tone 2	Tone 5
21	554Hz/440Hz @ 1Hz Alternating	0	0	1	0	1	0	Tone 2	Tone 5
22	544Hz @ 0.875 sec Intermittent	1	0	1	0	1	0	Tone 2	Tone 5
23	800Hz @ 2Hz Intermittent	0	1	1	0	1	0	Tone 6	Tone 5
24	800/1000Hz @ 50Hz Sweeping	1	1	1	0	1	0	Tone 29	Tone 5
25	2400/2900Hz @ 50Hz Sweeping	0	0	0	1	1	0	Tone 29	Tone 5
26	Bell	1	0	0	1	1	0	Tone 2	Tone 15
27	554Hz Continuous	0	1	0	1	1	0	Tone 26	Tone 5
28	440Hz Continuous	1	1	0	1	1	0	Tone 2	Tone 5
29	800/1000Hz @ 7Hz Sweeping	0	0	1	1	1	0	Tone 7	Tone 5
30	300Hz Continuous	1	0	1	1	1	0	Tone 2	Tone 5
31	660/1200Hz @ 1Hz Sweeping	0	1	1	1	1	0	Tone 26	Tone 5
32	Two tone chime	1	1	1	1	1	0	Tone 26	Tone 15
33	745Hz @ 1Hz Intermittent	0	0	0	0	0	1	Tone 2	Tone 5
34	1000 & 2000Hz @ 0.5 sec Alternating - Singapore	1	0	0	0	0	1	Tone 38	Tone 45
35	420Hz @ 0.625 Sec Australian Alert	0	1	0	0	0	1	Tone 36	Tone 5
36	500-1200Hz 3.75 sec /0.25 sec Australian Evac.	1	1	0	0	0	1	Tone 35	Tone 5
37	1000Hz Continuous - PFEER Toxic Gas	0	0	1	0	0	1	Tone 9	Tone 45
38	2000Hz Continuous	1	0	1	0	0	1	Tone 34	Tone 45
39	800Hz 0.25 sec on, 1 sec off Intermittent	0	1	1	0	0	1	Tone 23	Tone 17
40	544Hz (100mS)/440Hz (400mS) - NF S 32-001	1	1	1	0	0	1	Tone 31	Tone 27
41	Motor Siren - slow rise to 1200Hz	0	0	0	1	0	1	Tone 2	Tone 5
42	Motor Siren - slow rise to 800Hz	1	0	0	1	0	1	Tone 2	Tone 5
43	1200Hz Continuous	0	1	0	1	0	1	Tone 2	Tone 5
44	Motor Siren - slow rise to 2400Hz	1	1	0	1	0	1	Tone 2	Tone 5
45	1KHz 1s on, 1s off Intermittent - PFEER Gen. Alarm	0	0	1	1	0	1	Tone 38	Tone 34

SWITCH POSITION EXPLANATION

1 = Switch in the ON position.
 0 = Switch in the OFF position.