

IS-mini range

Intrinsically Safe Ex II 1G EEx ia IIC T4

- Ex II 1G EEx ia IIC T4 (-40°C ≤ Ta ≤ +60°C)
- Rated for Zone 0, 1 & 2, Gas group IIC
- ABS flame retardant UL94V0 & 5VA housings
- Colour: Red RAL3000, [Grey RAL7038 on request]
- Sealed to IP65
- Terminals accept 0.5 to 2.5mm² cables.
- Operating temperature : -40 to +60°C
- Storage temperature : -40 to +70°C
- Relative humidity : 90% at 50°C
- Installation : May be powered from any certified Zener barrier whose output parameters do not exceed :
Uo : 28VDC Io : 93mA Po : 660mW
or from any galvanic isolator specified by the system certificates.
- 2 x M20 knockouts.

- Standard : EN50014: 1997+ A1 & A2
EN50020: 2002
EN50284: 1999
- Certificate number : 05 ATEX2084X

IS-minialarm: Alarm Sounder - [IS-mA1]

- Output: 100dB(A) @ 1metre
- 49 alarm tone configurations (PFEER/UKOOA compliant)
- 3 stage alarm.
- Auto synchronised sound output
- Effective range at 1 kHz : 40m
- Voltage : 16-28vdc via Zener barrier or galvanic isolator
- End of line resistor certified
- Input overload and reverse current protection
- Current : 25mA typical when powered from 24v supply via 28v 3000hm Zener barrier.

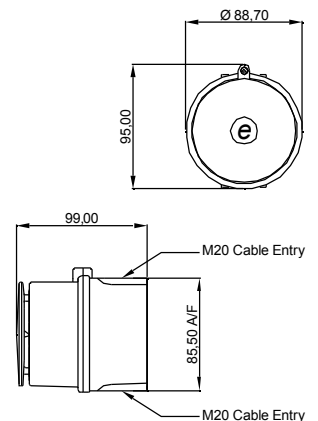

IS-minialite: L.E.D Beacon - [IS-mB1]

- Array of 6 high intensity L.E.D's.
- Colours available: Red, Amber, Blue & Green
- Prismatic lens optimises L.E.D effectiveness.
- 2 flash modes: Double flash @ 2Hz and 1Hz
- Voltage : 16-28vdc via Zener barrier or galvanic isolator
- End of line resistor certified
- Input overload and reverse current protection
- Current : 25mA typical when powered from 24v supply via 28v 3000hm Zener barrier.

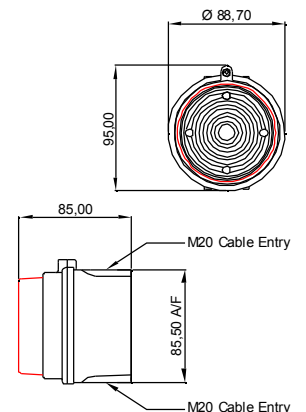

IS-minialert: Alarm Sounder & Beacon - [IS-mC1]

- All the features of the IS-minialarm and IS-minialite in a compact combined housing.
- Only one Zener barrier or galvanic isolator required to run both sounder & beacon.
- Current : 48mA typical when powered from 24v supply via 28v 3000hm Zener barrier.

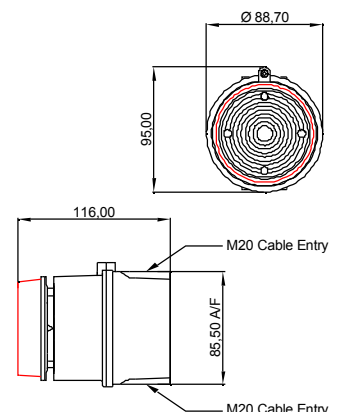

Dimensions are in millimetres.

- IS-minialarm and IS-minialert tone frequency table

Stage 1	Frequency Description		Stage 2	Stage 3
Tone 1	340 Hz Continuous		Tone 2	Tone 5
Tone 2	800/1000Hz @ 0.25 sec Alternating		Tone 17	Tone 5
Tone 3	500/1200Hz @ 0.3Hz 0.5 sec Slow Whoop		Tone 2	Tone 5
Tone 4	800/1000Hz @ 1Hz Sweeping		Tone 6	Tone 5
Tone 5	2400Hz Continuous		Tone 3	Tone 20
Tone 6	2400/2900Hz @ 7Hz Sweeping		Tone 7	Tone 5
Tone 7	2400/2900Hz @ 1Hz Sweeping		Tone 10	Tone 5
Tone 8	500/1200/500Hz @ 0.3Hz Sweeping		Tone 2	Tone 5
Tone 9	1200/500Hz @ 1Hz - DIN / PFEER P.T.A.P.		Tone 15	Tone 2
Tone 10	2400/2900Hz @ 2Hz Alternating		Tone 7	Tone 5
Tone 11	1000Hz @ 1Hz Intermittent		Tone 2	Tone 5
Tone 12	800/1000Hz @ 0.875Hz Alternating		Tone 4	Tone 5
Tone 13	2400Hz @ 1Hz Intermittent		Tone 15	Tone 5
Tone 14	800Hz 0.25sec on, 1 sec off Intermittent		Tone 4	Tone 5
Tone 15	800Hz Continuous		Tone 2	Tone 5
Tone 16	660Hz 150mS on, 150mS off Intermittent		Tone 18	Tone 5
Tone 17	544Hz (100mS)/440Hz (400mS) - NF S 32-001		Tone 2	Tone 27
Tone 18	660Hz 1.8sec on, 1.8sec off Intermittent		Tone 2	Tone 5
Tone 19	1.4KHz-1.6KHz 1s, 1.6KHz-1.4KHz 0.5s -NFC48-265		Tone 2	Tone 5
Tone 20	660Hz Continuous		Tone 2	Tone 5
Tone 21	554Hz/440Hz @ 1Hz Alternating		Tone 2	Tone 5
Tone 22	544Hz @ 0.875 sec. Intermittent		Tone 2	Tone 5
Tone 23	800Hz @ 2Hz Intermittent		Tone 6	Tone 5
Tone 24	800/1000Hz @ 50Hz Sweeping		Tone 29	Tone 5
Tone 25	2400/2900Hz @ 50Hz Sweeping		Tone 29	Tone 5
Tone 26	Bell		Tone 2	Tone 15
Tone 27	554Hz Continuous		Tone 26	Tone 5
Tone 28	440Hz Continuous		Tone 2	Tone 5
Tone 29	800/1000Hz @ 7Hz Sweeping		Tone 7	Tone 5
Tone 30	300Hz Continuous		Tone 2	Tone 5
Tone 31	660/1200Hz @ 1Hz Sweeping		Tone 26	Tone 5
Tone 32	Two tone chime.		Tone 26	Tone 15
Tone 33	745Hz @ 1Hz Intermittent		Tone 2	Tone 5
Tone 34	1000 & 2000Hz @ 0.5 sec Alternating - Singapore		Tone 38	Tone 45
Tone 35	420Hz @ 0.625 sec Australian Alert		Tone 36	Tone 5
Tone 36	500-1200Hz 3.75sec /0.25sec. Australian Evac.		Tone 35	Tone 5
Tone 37	1000Hz Continuous - PFEER Toxic Gas		Tone 9	Tone 45
Tone 38	2000Hz Continuous		Tone 34	Tone 45
Tone 39	800Hz 0.25sec on, 1 sec off Intermittent		Tone 23	Tone 17
Tone 40	544Hz (100mS)/440Hz (400mS) - NF S 32-001		Tone 31	Tone 27
Tone 41	Motor Siren - slow rise to 1200 Hz		Tone 2	Tone 5
Tone 42	Motor Siren - slow rise to 800 Hz		Tone 2	Tone 5
Tone 43	1200 Hz Continuous		Tone 2	Tone 5
Tone 44	Motor Siren - slow rise to 2400 Hz		Tone 2	Tone 5
Tone 45	1KHz 1s on, 1s off Intermittent - PFEER Gen. Alarm		Tone 38	Tone 34
Tone 46	1200/500Hz @ 1Hz - DIN / PFEER P.T.A.P.		Tone 47	Tone 37
Tone 47	1KHz 1s on, 1s off Intermittent - PFEER Gen. Alarm		Tone 46	Tone 37
Tone 48	420Hz @ 0.625 sec Australian Alert		Tone 49	Tone 5
Tone 49	500-1200Hz 3.75sec /0.25sec. Australian Evac.		Tone 26	Tone 37

Ordering Information:

IS-minialarm: IS-mA1-R

IS-minialite: IS-mB1-R/x {where x denotes colour of L.E.D: R=Red, A=Amber, B=Blue, G=Green}

IS-minialert: IS-mC1-R/x {where x denotes colour of L.E.D: R=Red, A=Amber, B=Blue, G=Green}